



Hydraulic Hose Harness

Safety restraining system
designed to prevent whipping



HYDRAULIC HOSE HARNESS

The Slingco Hydraulic Hose Harness limits the whip or 'travel' of a pressurized hose in the event of it becoming detached from its fitting.

The damage caused by a violently whipping hose, especially one operating under high pressure, can pose severe health and safety concerns - not to mention financial and legal ramifications - for any company. The Slingco Hydraulic Hose Harness (H3) addresses this concern by limiting the whip or 'travel' of the pressurized hose if it breaks free from its hose fitting.

Features and benefits

- Designed to prevent whipping in the event of a pressurized hose becoming detached from the fitting
- Helps prevent injury to operators and damage to equipment near a hose failure
- Ideal for use in Oil and Gas applications, mining and manufacturing for pressurized fluid and air hoses
- Double eye, double weave mesh construction, with reinforced thimble eyes
- High strength galvanized steel

Note: all proper health and safety procedures must be carried out in addition to the use of an H3 Harness.

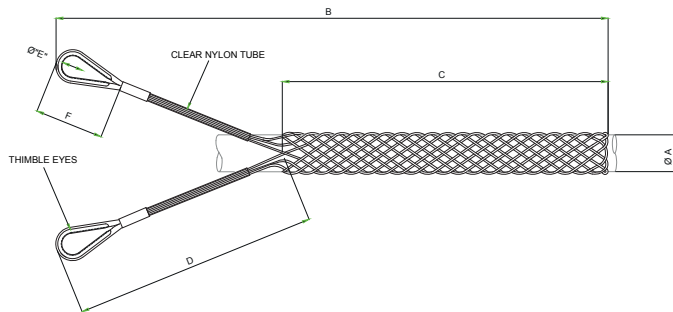

- ✓ Helps prevent injury to operators and damage to equipment near a hose failure
- ✓ Ideal for use in Oil and Gas applications, mining and manufacturing for pressurized fluid and air hoses
- ✓ Addresses both health and safety concerns and potential financial and legal ramifications

Slingco part no.	Ø A Nominal	Range	Lattice weave	B Length	C Length	D Length	Ø E	F Length	Approximate Break Load
DOUBLE THIMBLE EYE DOUBLE WEAVE GALVANIZED STEEL									
ZCS5363	32mm 1.25"	25 - 38mm 1.0 - 1.5"	Double	864mm 34"	660mm 26"	203mm 8"	25.4mm 1.0"	68mm 2.67"	4,911 kgs. 11,000 lbs
ZCS5364	51mm 2.0"	38 - 63mm 1.5 - 2.5"	Double	1270mm 50"	1016mm 40"	254mm 10"	25.4mm 1.0"	68mm 2.67"	8,928 kgs 20,000 lbs
ZCS5365	76mm 3.0"	63 - 89mm 2.5 - 3.5"	Double	1321mm 52"	1067mm 42"	254mm 10"	25.4mm 1.0"	68mm 2.67"	9,821 kgs 22,000 lbs
ZCS5366	102mm 4.0"	89 - 114mm 3.5 - 4.5"	Double	1422mm 56"	1118mm 44"	305mm 12"	25.4mm 1.0"	68mm 2.67"	12,053 kgs 27,000 lbs
ZCS5367	127mm 5.0"	114 - 140mm 4.5 - 5.5"	Double	1524mm 60"	1219mm 48"	305mm 12"	25.4mm 1.0"	68mm 2.67"	13,839 kgs 31,000 lbs

Lengths B and C when on nominal mandrel Ø A