

BRIDGE TYPE CABLE LAYING ROLLER



KEY FEATURES

- ✓ Available in different configurations
- ✓ Zinc plated
- ✓ Suitable for power, telecoms and utility installs

They are of steel construction with zinc plating for general purpose cable installation work in trenches. They are suitable for power, telecoms and utility installations, and can bridge existing cables in trenches or ducts.



GET IN TOUCH

- ☎ 1 888 685 9478
- ✉ sales@slingcoamerica.com

BRIDGE TYPE CABLE LAYING ROLLER

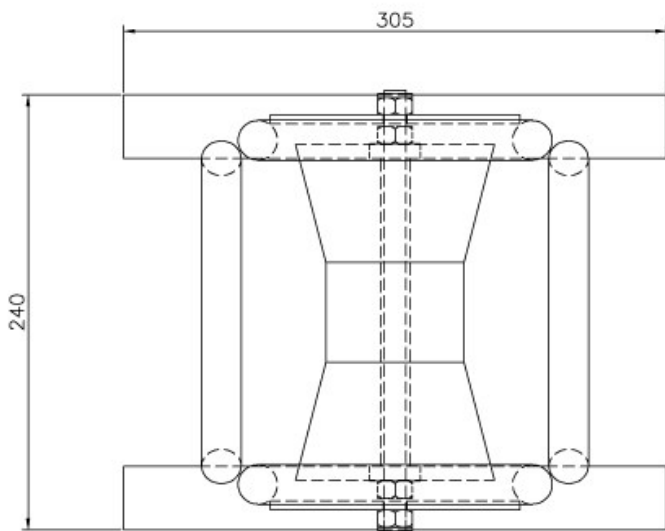
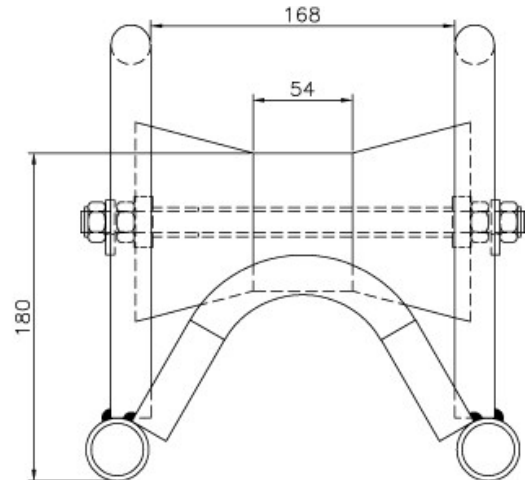
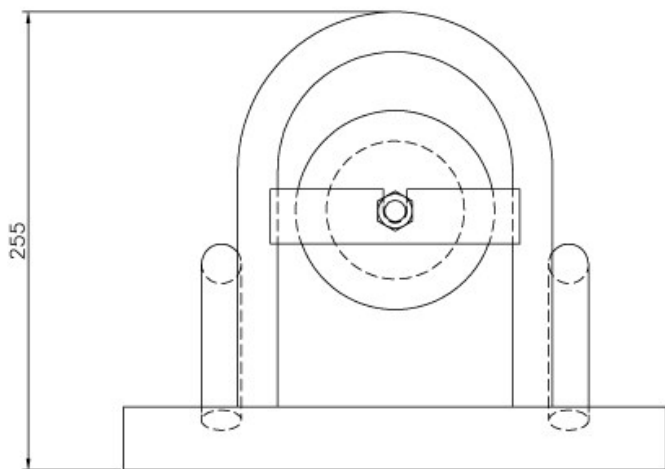

Slingco Part No.	Base footprint (in)	Base footprint (mm)	Height to top of roller (in)	Height to top of roller (mm)	Handle height (in)	Handle height (mm)
ZGP2395	12 x 9.5	305 x 240	7.125	180	10	255

This information is for marketing purposes only. The details contained herein is presented as general information and no representation or warranty is expressly or impliedly given as to its accuracy, completeness or correctness. It does not constitute part of a legal offer or contract. For technical specifications, please contact Slingco America, Inc.

Dimensions

The figures shown are indicative only. Fully dimensioned data-sheets are available on request. Nominal figures/actuals are as per data-sheet with tolerances of +/- 10%. Please contact us if you have any questions.

Range dimension overlaps If the cable, rope or hose you have lies where ranges overlap, e.g. 1" when sizing is 0.5-1.00 and 1.00-1.5 we recommend that you select your cable grip to achieve break load first. If tensile strengths are equal or both adequate, choose the smaller of the two. Please contact us if you have any questions.



GET IN TOUCH

1 888 685 9478

sales@slingcoamerica.com