

COMPACT BRIDGE TYPE CABLE LAYING ROLLER

⚠ WARNING

Cancer and Reproductive Harm: www.P65Warnings.ca.gov



KEY FEATURES

- ✓ Heavy duty tubular frame straight line bridge roller
- ✓ Fitted with hoops to fit over previously laid cables
- ✓ 76mm diameter aluminium roller
- ✓ Oil impregnated maintenance free bushes fitted
- ✓ Bright zinc plated finish
- ✓ 90mm diameter cable capacity
- ✓ Weight 2.5Kg

This is a compact cable roller for use in narrow trenches and/or in confined areas.

* The specification can be adjusted, if required, to suit your individual requirements.

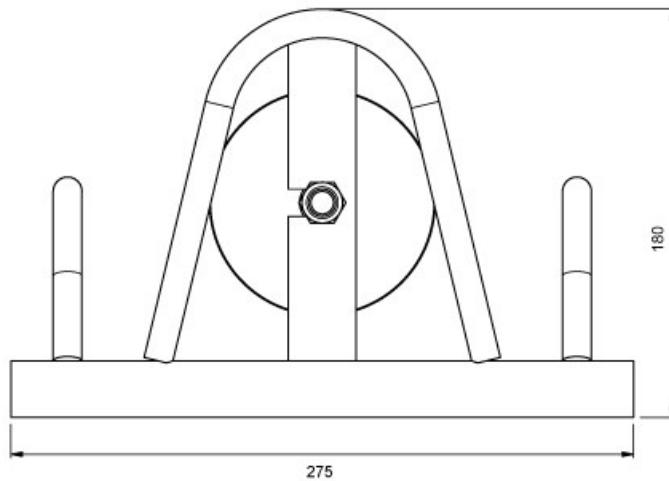
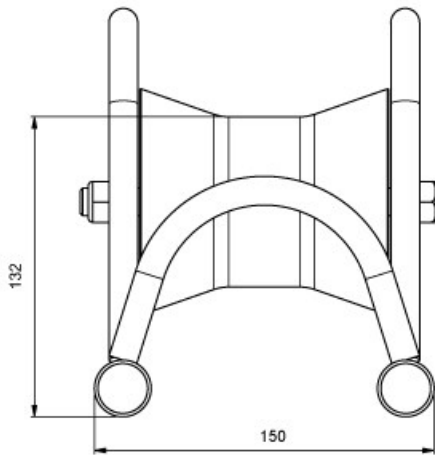

Slingco Part No.	Base Footprint (mm)	Height (mm)	Max Cable Diameter (mm)	Weight (kg)
ZGP8270	275 x 150	180	90	2.5

Slingco Part No.	Base Footprint (in)	Height (in)	Max Cable Diameter (in)	Weight (lb)
ZGP8270	10.83 x 5.9	7	3.54	5.5

This information is for marketing purposes only. The details contained herein is presented as general information and no representation or warranty is expressly or impliedly given as to its accuracy, completeness or correctness. It does not constitute part of a legal offer or contract. For technical specifications, please contact Slingco Limited.



GET IN TOUCH

☎ 01706 855 558

✉ sales@slingco.com

COMPACT BRIDGE TYPE CABLE LAYING ROLLER

Dimensions

The figures shown are indicative only. Fully dimensioned data-sheets are available on request. Nominal figures/actuals are as per data-sheet with tolerances of +/-10%. Please contact us if you have any questions.

Range dimension overlaps If the cable, rope or hose you have lies where ranges overlap, e.g. 1" when sizing is 0.5-1.00 and 1.00-1.5 we recommend that you select your cable grip to achieve break load first. If tensile strengths are equal or both adequate, choose the smaller of the two. Please contact us if you have any questions.



GET IN TOUCH

 01706 855 558

 sales@slingco.com

Slingco Ltd, Gateway Business Park, New Hall Hey Road, Rawtenstall, BB4 6JG t: 01706 855558
Slingco America Inc, 3100 Jonquil Drive SE, Smyrna, Georgia, 30080, USA t: 888 685 9478