

DISTRIBUTION STRINGING BLOCKS & ACCESSORIES

LIGHTWEIGHT, RELIABLE AND VERSATILE



ZAB4004

- Distribution Stringing Blocks
- Crossarm Ratchet Strap Bracket
- Crossarm Brackets
- Y-Ball and U-Ball Clevises
- Insulator Bracket

Distribution Stringing Blocks

Slingco offers two lightweight, rugged, reliable and durable aluminium distribution stringing blocks.

Used in conjunction with purpose-designed accessories, the Slingco 7" blocks have proven extremely popular with utility operators and their contractors for the exceptional versatility they offer in terms of installation applications and locations.

Their low-friction bearings deliver high efficiency, which helps to maximise stringing distances while minimising pulling tensions and reducing loads on stringing equipment.

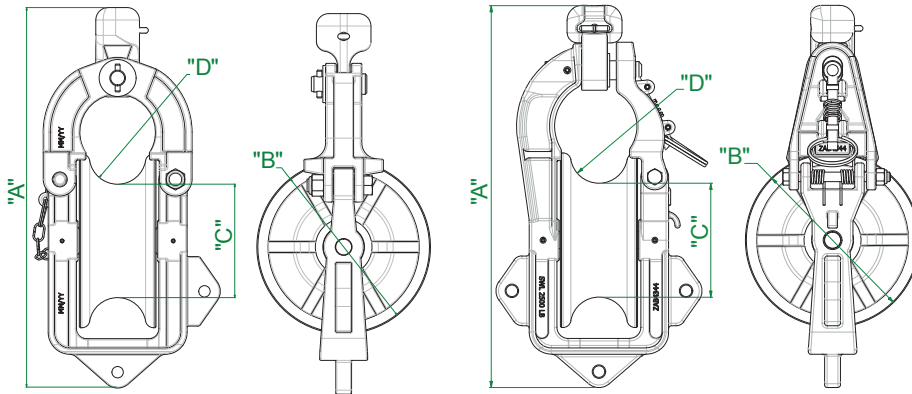

ZAB4004

ZAB4344

Slingco Part No.	Description	Weight		WLL		Height "A"		Sheave Diameter "B"		Bottom of Groove "C"		Groove Radius "D"	
		lb	kg	lb	kg	in	mm	in	mm	in	mm	in	mm
ZAB4004	7" Pin Gate Aluminium Distribution Block	8.3	3.76	2,500	1,134	15.125	384.2	7	177.8	4.5	114.3	2.25	57.15
ZAB4344	7" Spring Gate Aluminium Distribution Block	9.2	4.17	2,500	1,134	15.344	389.74	7	177.8	4.5	114.3	2.25	57.15

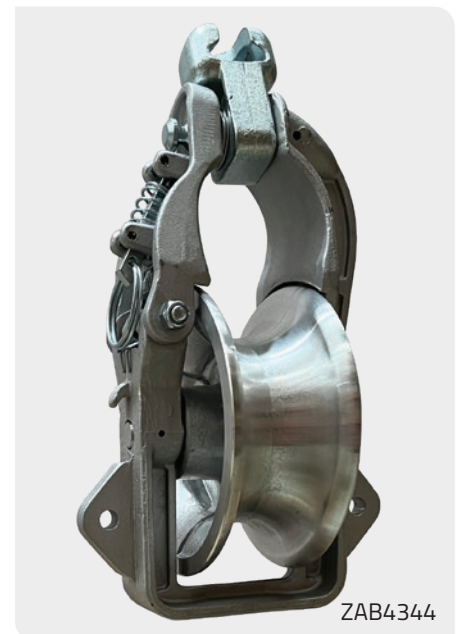

ZAB4344

DISTRIBUTION STRINGING BLOCKS & ACCESSORIES: LIGHTWEIGHT, RELIABLE AND VERSATILE



ZMI10017



ZMI10018



ZMI14338



ZMI14345



ZMI14346

Crossarm Ratchet Strap Bracket

Used in conjunction with Slingco's 7" Stringing Blocks, the Crossarm Ratchet Strap Bracket (ZMI14338) can be mounted on wooden, fibreglass or composite crossarms, as well as concrete, wood, or steel poles. This versatile crossarm bracket with ratchet strap allows stringing blocks to be mounted horizontally or vertically.

Strap length is 60" (1500 mm), with a WLL of 2500 lb (1,133 kg).

Crossarm Brackets

Slingco Crossarm Brackets are designed for easy attachment of distribution blocks to crossarms. Securely mount distribution blocks to crossarms at three convenient angles based upon the needs of your pull. Quick release pin for attachment of distribution block. Fits most crossarm sizes.

Two styles available: full frame (ZMI10018) and partial frame (ZMI10017).



CSB09094

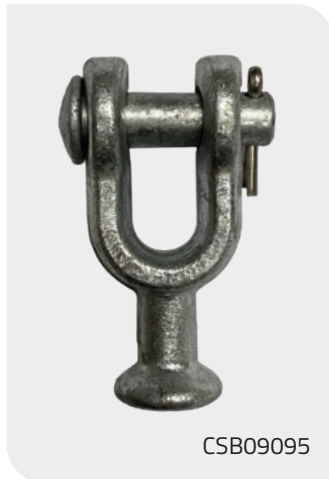

CSB09095

Insulator Bracket

Used in conjunction with Slingco 7" Stringing Blocks, the Slingco Insulator Bracket with bolt (ZMI14345) or handle (ZMI14346) fit insulators with a neck range of 2-1/8" – 3-1/2". The Slingco insulator brackets have a WLL of 2,500 lb (1,133 kg) in the vertical direction and 1,500 lb (680 kg) in the horizontal direction.

Slingco Part No.	Description	WLL	
		lb	kg
ZMI10017	Partial Frame Crossarm Bracket	2,500	1,133
ZMI10018	Full Frame Crossarm Bracket	2,500	1,133
ZMI14338	Crossarm Ratchet Strap Bracket	2,500	1,133
ZMI14345	Insulator Bracket with Bolt	2,500	1,133
ZMI14346	Insulator Bracket with Handle	2,500	1,133
CSB09094	Y Ball Clevis	30,000	13,600
CSB09095	U Ball Clevis	30,000	13,600

WARNING
Cancer and Reproductive Harm
www.P65Warnings.ca.gov

FOR ANY ENQUIRIES CALL TODAY ON
+61 3 8840 6556



Slingco Australia Pty. Ltd.
L11, 1 York Street, Sydney, NSW 2000, Australia
Tel: +61 3 8840 6556 · sales@slingcoaustralia.com.au

slingcoaustralia.com.au