

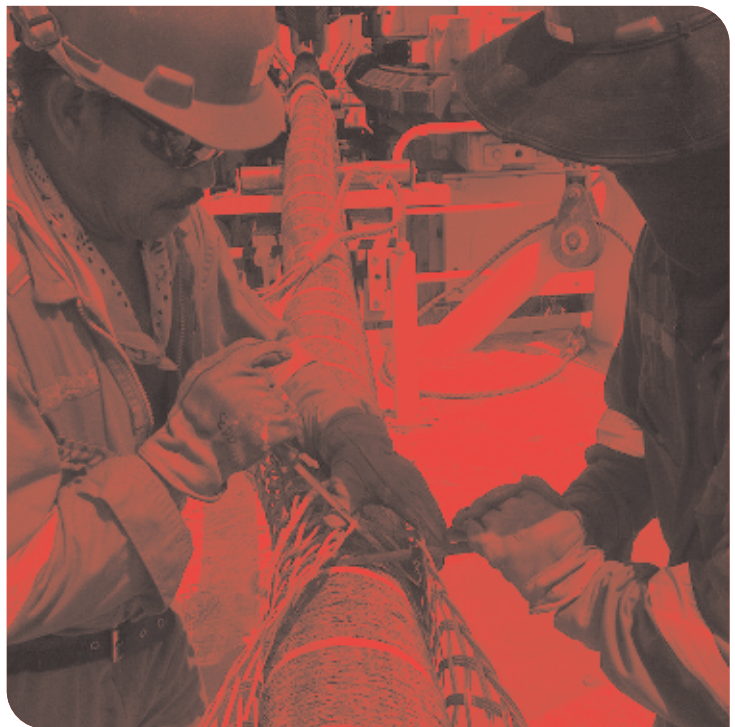

**CABLE INSTALLATION  
AND SUPPORT  
MADE A WHOLE  
LOT EASIER**



CABLE PULLING · CABLE SUPPORT · CABLE CONTROL & GUIDANCE · TOOLS & ACCESSORIES



# A GLOBAL BUSINESS BUILT ON QUALITY, INNOVATION, SERVICE ...AND REAL FAMILY TIES

Welcome to Slingco, a world-leading supplier of cable sock and wire rope. Founded by our father, Chris Dykins, more than 40 years ago, Slingco remains a family-owned business but has evolved into an expert design and manufacturing operation, producing high quality cable socks, wire rope assemblies and more - products that are renowned for high performance in quality-critical applications.

Slingco operates out of regional bases in the UK and USA, but you'll find our products around the world, making heavy-duty cable and conductor installation and support a whole lot easier for people working in industries as varied as oil and gas, marine and offshore, public utilities, civil engineering, aerospace, transport, the military, performing arts, vehicle building, construction and more.

You can't make mistakes when you're dealing with products like ours. Too much depends on them. That's why we're obsessive about quality and innovation in design and manufacturing, and why nothing leaves our hands that isn't 100% dependable.

Because we understand exactly what your operation needs, we also know cost is a factor. We keep our prices realistic and hold a vast range of stock for fast – even same day – delivery.

We're brothers, partners and the driving force behind Slingco, but we're only a small part of the whole picture. We've got a fantastic team of skilled people who share our obsession with quality and great service. We're proud of every one of them.

Together, we're going to carry on developing outstanding products. We're going to carry on getting them out to you in record time. And we're going to carry on being the sort of company it's a pleasure to deal with.

NICK DYKINS  
CEO, SLINGCO LIMITED

MATT DYKINS  
PRESIDENT, SLINGCO AMERICA

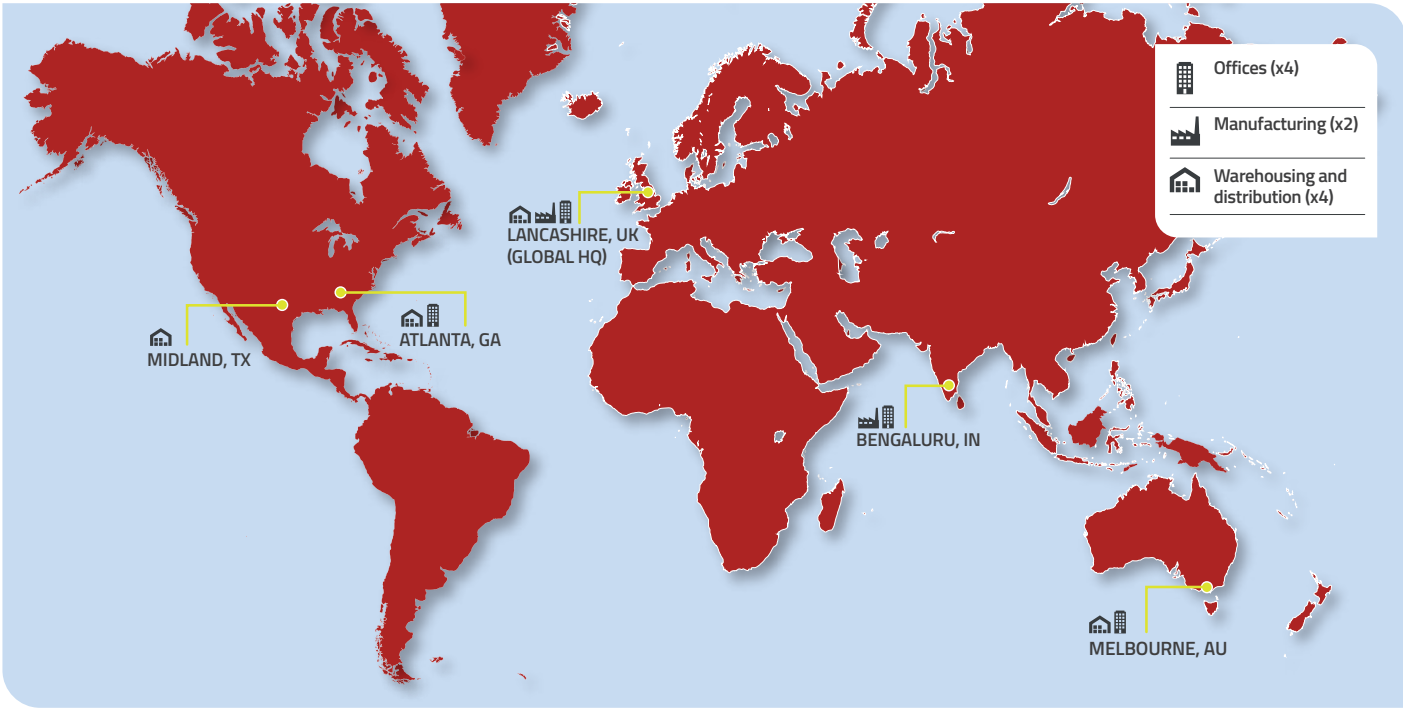

**WARNING**  
Cancer and Reproductive Harm [www.P65Warnings.ca.gov](http://www.P65Warnings.ca.gov)

Some of the products in this catalogue are subject to Prop65 health warnings. For details, please contact us.

**PLEASE NOTE:** While every effort has been made to ensure accuracy of all content in this catalogue, please confirm with your Slingco contact any critical information before purchase.



## CABLE PULLING

A Type - High Strength Cable Sock	4
Feed Tube	4
MU Type - High Strength Cable Sock	5
MD Type - Medium Duty Pulling Sock	5
LD Type - Light Duty Pulling Sock	5
SE Type - Single Eye Sock	6
Single Eye (Long) Double Weave Pulling Sock	6
OS Type - Offset Eye Sock	7
DE Type - Double Eye Sock	7
LU Type - Lace Up Sock	8
Open Ended Sock	8
Fibre Optic Cable Sock	9
Splicing Sock - Rotating Swivel Link	9
NS Type - Single Eye Aramid Cable Sock	10-11
ND Type - Double Eye Aramid Cable Sock	10-11
NO Type - Offset Eye Aramid Cable Sock	10-11
Standard Duty Hose Restraint Cable Socks - Double Eye	12
Standard Duty Hose Restraint Cable Socks - Four Eye	12
Heavy Duty Hose Restraint Socks - Double Eye	13
Whipcheck	13
Sub-Sea Marine Socks	14-15

## TOOLS & ACCESSORIES

Line Pulling Swivels	16
Directional Drilling Swivels	17
C Connectors	17
Connectors: 90°, Rope To Rope, Rope To Swivel	17
Bridge Type Cable Laying Roller	18
Edge Mount Manhole Lead-In Cable Roller (Heavy Duty)	18
Edge Mount Manhole Lead-In Cable Roller (Light Duty)	18
Heavy Duty 214mm Straight Line Cable Roller	19
Heavy Duty Triple Corner Cable Roller	19
Cable Drum Rotator	19
Banding Tools, Buckles And Bands	20-21
60 Ton Hydraulic Crimping Tool	22
100 Ton Hydraulic Crimping Tool	23
Mechanical Crimping Tools	24
Ratchet Cutters (ACSR)	24

## TOOLS & ACCESSORIES

Reel Lifter	25
Hand Line Tools	25
35Kv Jumper Clamp	26
Rubber Blanket Accessories	26
Pole Puller	27
Pole Stand	27
Dirt Tarps	28
Stay Wire Dispenser	28
Triplex Dispenser	28
3k Strap Hoist	29
Catchblock OHL Catenary Roller	29
Conductor Replacement Roller	30
Roblon High Voltage Pulling Rope	30
Multi Function Cable Robot	31
Bollard Clamp	31
Fibreglass Extension Arm	31
Distribution Stringing Blocks	32
Crossarm Brackets	33
Ball Clevises	33
Drive Wrench Assembly	34-35
Hex Kelly Bar Adapter	35
Square Head Adapter	35
Drive Wrench Lock Assembly	35
Drive Wrenches	35
Cross Coupling Protectors	36
Gauge and Splice Protectors	36
Dual Channel Cross Coupling Protectors	36
Mid-Joint Cable Protectors	37
Centralising Cable Protectors	37
Banded Cable Protectors	37
Bow Spring Centralisers	38
Rigid Centralisers	38

## IMPORTANT TECHNICAL INFORMATION

Cable Pulling Socks and Cable Support Socks	39
Single and Double Eye Cable Sock Instructions	40
Lace Up Cable Sock Instructions	41

### Helping you choose the right product

To help guide you and advise where our products are most commonly used we have created the following market logos which you will find adjacent each product in the catalogue.



**OHL**  
(Transmission & Distribution)



**CONSTRUCTION**



**UNDERGROUND**  
(Transmission & Distribution)



**TELECOMS**



**MINING**



**OIL & GAS**



**SUB-SEA**



**INDUSTRIAL**



## A TYPE - HIGH STRENGTH CABLE SOCK

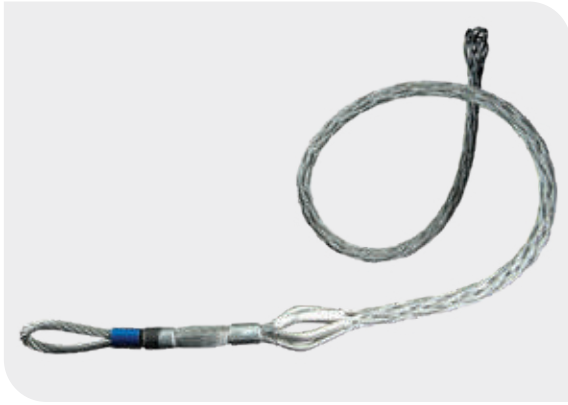

The strongest cable sock we produce; can be used for metal wire and synthetic rope pulls. Perfect for overhead transmission and distribution line pulling or any applications with heavy load ratings, e.g. gas, electric railroad, rigging lines and construction pulls. When pulling synthetic rope use a Slingco Feed Tube (see below) to make rope insertion a breeze. To avoid the effects of torsion a line pulling swivel that rotates under load should be used. Galvanised steel and colour coded for ease of identification.

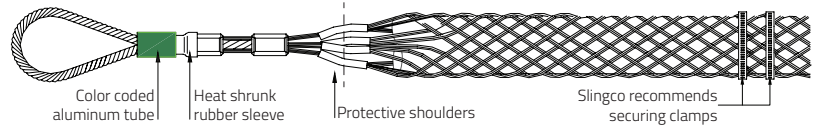

Slingco Part No.	Colour Code	Rope Diameter		Conductor Diameter		Overall Length		Lattice Length		Approx. Break Load	
		in	mm	in	mm	in	mm	in	mm	lb	kg
ZCS1799	Black	0.25 - 0.65	6 - 16	0.19 - 0.40	5 - 10	38	965	28	710	7,000	3,180
ZCS1800	Dark Green	0.50 - 0.90	13 - 23	0.38 - 0.63	9.7 - 16	51	1,300	37	940	14,000	6,360
ZCS1801	Red	0.75 - 1.10	19 - 28	0.63 - 0.88	16 - 22	74	1,880	58	1,473	20,000	9,072
ZCS5543	Brown			0.75 - 1.10	19 - 28	81	2,060	62	1,579	30,700	13,925
ZCS1802	Blue	1.00 - 1.50	25 - 38	0.88 - 1.13	22 - 29	80	2,032	61	1,549	30,700	13,955
ZCS1803	Yellow	1.25 - 1.70	32 - 43	1.13 - 1.38	29 - 35	112	2,845	90	2,299	47,000	21,360
ZCS1804	Aluminium	1.50 - 2.10	38 - 53	1.38 - 1.90	35 - 50	119	3,020	92	2,336	67,000	30,455

- The break loads and lengths shown above are as a guide only – for exact calculations please refer to data sheets which can be obtained from [sales@slingcoaustralia.com.au](mailto:sales@slingcoaustralia.com.au)
- For socks/stockings above 140mm diameter please contact – [sales@slingcoaustralia.com.au](mailto:sales@slingcoaustralia.com.au)

## FEED TUBE



Due to the tight construction of the A Type cable sock, we recommend using the Slingco Feed Tube when inserting cable or rope into the socks. For ease of use, our feed tubes are colour-coded to match the A Type Cable sock.

Slingco Part No.	Tube to fit rope diameter		Feed tube length		Matches Slingco cable sock part no.	Cable sock colour
	in	mm	in	mm		
FTU1890	0.25 - 0.65	6 - 16	28	713	ZCS1799	Black
FTU1891	0.50 - 0.90	13 - 23	40	1,018	ZCS1800	Dark Green
FTU1892	0.75 - 1.10	19 - 28	52	1,324	ZCS1801	Red
FTU1893	1.00 - 1.50	25 - 38	67	1,706	ZCS1802	Dark Blue
FTU1894	1.25 - 1.70	32 - 43	83	2,113	ZCS1803	Yellow
FTU1895	1.50 - 2.10	38 - 53	96	2,444	ZCS1804	Aluminium

- The break loads and lengths shown above are as a guide only – for exact calculations please refer to data sheets which can be obtained from [sales@slingcoaustralia.com.au](mailto:sales@slingcoaustralia.com.au)
- For socks/stockings above 140mm diameter please contact – [sales@slingcoaustralia.com.au](mailto:sales@slingcoaustralia.com.au)



## MU TYPE - HIGH STRENGTH CABLE SOCK



This sock's triple weave construction is ideal for heavy loads. MU cable socks are colour coded for ease of identification. Perfect for stringing overhead transmission and distribution lines and heavy-load pulls of any kind. Use with bare or insulated cable, conductor or wire. The flexible eye connects with Slingco line pulling swivels for trouble free pulling applications. Made of galvanised steel.

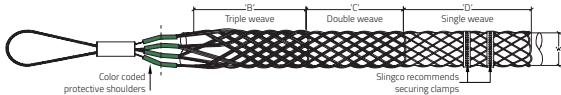

Slingco Part No.	Colour Code	Range		Lattice Length		Approx. Break Load	
		in	mm	in	mm	lb	kg
ZCS1710	Dark Green	0.25 - 0.50	6-12	31	787	7,000	3,170
ZCS1711	Brown	0.50 - 0.75	12-19	45	1,143	10,500	4,760
ZCS1712	Light Blue	0.75 - 1.00	19-25	43	1,092	14,100	6,395
ZCS1713	Gold	1.00 - 1.25	25-32	65	1,651	25,000	11,340
ZCS1714	Black	1.25 - 1.50	32-38	59	1,499	31,000	14,065
ZCS1715	Red	1.50 - 1.75	38-44	82	2,083	31,000	14,065
ZCS1716	Dark Blue	1.75 - 2.25	44-57	82	2,083	49,000	22,230

- The break loads and lengths shown above are as a guide only – for exact calculations please refer to data sheets which can be obtained from [sales@slingcoaustralia.com.au](mailto:sales@slingcoaustralia.com.au)
- For socks/stockings above 140mm diameter please contact – [sales@slingcoaustralia.com.au](mailto:sales@slingcoaustralia.com.au)

## MD TYPE - MEDIUM DUTY PULLING SOCK



Quick and easy to attach and remove, these cable socks are suitable for all common conductors, e.g. Horse, Lynx, Upas, Zebra and Araucaria plus earth wires OPGW. The flexible eye connects with Slingco line pulling swivels for trouble-free pulling applications. Made of galvanised steel.

Slingco Part No.	Colour Code	Range		Lattice Length		Min. Break Load		WLL 3:1	
		in	mm	in	mm	lb	kg	lb	kg
ZCS7229	Green	0.31 - 0.51	8 - 13	24	610	4,960	2,250	1,653	750
ZCS7230	Brown	0.47 - 0.75	12 - 19	24	610	7,452	3,380	2,484	1,127
ZCS7231	Light Blue	0.75 - 0.98	19 - 25	24	610	12,214	5,540	4,071	1,847
ZCS7232	Gold	0.98 - 1.26	25 - 32	24	610	21,054	9,550	7,018	3,183

- The break loads and lengths shown above are as a guide only – for exact calculations please refer to data sheets which can be obtained from [sales@slingcoaustralia.com.au](mailto:sales@slingcoaustralia.com.au)
- For socks/stockings above 140mm diameter please contact – [sales@slingcoaustralia.com.au](mailto:sales@slingcoaustralia.com.au)

## LD TYPE - LIGHT DUTY PULLING SOCK

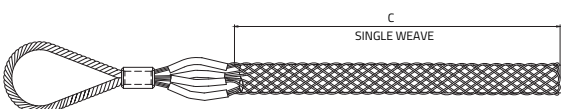
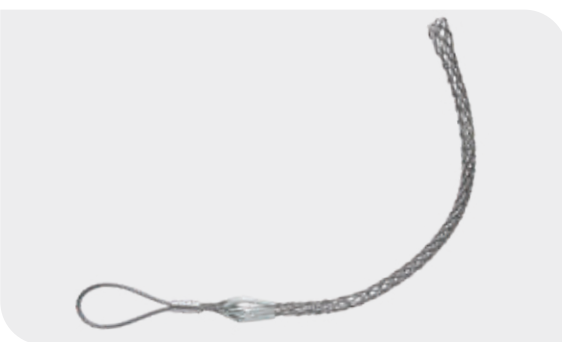

Quick and easy to attach and remove, these cable socks are suitable for all common conductors, e.g. Horse, Lynx, Upas, Zebra and Araucaria plus earth wires OPGW. The flexible eye connects with Slingco line pulling swivels for trouble-free pulling applications. Made of galvanised steel.

Slingco Part No.	Colour Code	Range		Lattice Length		Min. Break Load		WLL 3:1	
		in	mm	in	mm	lb	kg	lb	kg
ZCS7233	Green	0.40 - 0.51	10 - 13	24	610	2,469	1,120	823	373
ZCS7234	Brown	0.51 - 0.75	13 - 19	24	610	3,704	1,680	1,235	560
ZCS7235	Light Blue	0.75 - 0.98	19 - 25	24	610	4,938	2,240	1,646	747
ZCS7236	Gold	0.98 - 1.50	25 - 38	24	610	9,877	4,480	3,292	1,493

- The break loads and lengths shown above are as a guide only – for exact calculations please refer to data sheets which can be obtained from [sales@slingcoaustralia.com.au](mailto:sales@slingcoaustralia.com.au)
- For socks/stockings above 140mm diameter please contact – [sales@slingcoaustralia.com.au](mailto:sales@slingcoaustralia.com.au)

SE TYPE - SINGLE EYE SOCK



Ideal for pulling light to medium loads; typical application - 'standard pull' of single or group of cables, where additional support is unnecessary, or if used in conjunction with other cable socks.

Slingco Part No.	Range		Lattice Weave	Lattice length		Overall Length		Approx. Break Load	
	in	mm		in	mm	in	mm	lb	kg
<b>SINGLE EYE STANDARD SOCK - GALVANISED</b>									
ZCS0320	0.25 - 0.50	6 - 13	Single	9	230	12	305	1,680	760
ZCS0321	0.50 - 0.75	13 - 19	Single	14	355	17	430	2,240	1,015
ZCS0322	0.75 - 1.00	19 - 25	Single	16	405	20	510	5,600	2,540
ZCS0323	1.00 - 1.50	25 - 38	Single	18	455	24	610	7,840	3,555
ZCS0324	1.50 - 2.00	38 - 50	Double	21	535	29	735	11,200	5,080
ZCS0325	2.00 - 2.50	50 - 63	Double	24	610	34	865	11,200	5,080
ZCS0326	2.50 - 3.50	63 - 89	Double	27	685	39	990	13,440	6,095
ZCS0327	3.50 - 4.50	89 - 115	Double	27	685	39	990	15,680	7,110
ZCS0821	4.50 - 5.50	115 - 140	Double	27	685	39	990	15,680	7,110
<b>SINGLE EYE STANDARD SOCK - 316 STAINLESS STEEL</b>									
ZCS1380	0.25 - 0.50	6 - 13	Single	9	230	12	305	1,344	610
ZCS1523	0.50 - 0.75	13 - 19	Single	14	355	17	430	1,792	810
ZCS1373	0.75 - 1.00	19 - 25	Single	16	405	20	510	4,480	2,030
ZCS1952	1.00 - 1.50	25 - 38	Single	18	455	24	610	6,272	2,845
ZCS1381	1.50 - 2.00	38 - 50	Double	21	535	29	735	8,960	4,065
ZCS1977	2.00 - 2.50	50 - 63	Double	24	610	34	865	8,960	4,065
ZCS1979	2.50 - 3.50	63 - 89	Double	27	685	39	990	10,752	4,875
ZCS1980	3.50 - 4.50	89 - 115	Double	27	685	39	990	12,544	5,690
ZCS1981	4.50 - 5.50	115 - 140	Double	27	685	39	990	12,544	5,690

- The break loads and lengths shown above are as a guide only – for exact calculations please refer to data sheets which can be obtained from [sales@slingcoaustralia.com.au](mailto:sales@slingcoaustralia.com.au)
- For socks/stockings above 140mm diameter please contact – [sales@slingcoaustralia.com.au](mailto:sales@slingcoaustralia.com.au)

SINGLE EYE (LONG) DOUBLE WEAVE PULLING SOCK



Flex eye general duty pulling grips. Made of galvanised wire these extra long socks with 900 mm double weave lattices are perfect for general light to medium duty pulling applications.

Slingco Part No.	Range		Lattice Weave	Lattice Length		Overall Length		Approx. Break Load	
	in	mm		in	mm	in	mm	lb	kg
<b>900 mm SERIES</b>									
ZCS12638	0.25-0.38	6 - 10	Double	35.4	900	46.7	1,186	3,316	1,504
ZCS12639	0.38-0.79	10 - 20	Double	35.4	900	46.7	1,186	4,101	1,860
ZCS12640	0.79-1.18	20 - 30	Double	35.4	900	46.7	1,186	4,974	2,256
ZCS12641	1.18-1.57	30 - 40	Double	35.4	900	46.7	1,186	8,148	3,696
ZCS12642	1.57-1.97	40 - 50	Double	35.4	900	47.04	1,195	12,103	5,490
ZCS12643	1.97-2.5	50 - 65	Double	35.4	900	47.04	1,195	12,103	5,490
ZCS12644	2.5-3.15	65 - 80	Double	35.4	900	47.04	1,195	16,138	7,320
ZCS12645	3.15-3.75	80 - 95	Double	35.4	900	47.04	1,195	16,138	7,320
ZCS12646	3.75-4.33	95 - 110	Double	35.4	900	47.04	1,195	23,398	10,613
ZCS12647	4.33-5.12	110 - 130	Double	35.4	900	47.04	1,195	23,398	10,613
ZCS12648	5.12-5.91	130 - 150	Double	35.4	900	47.04	1,204	23,398	10,613
ZCS12649	5.91-7.0	150 - 180	Double	35.4	900	48.1	1,223	28,078	12,736

## OS TYPE – OFFSET EYE SOCK



Similar to the SE Type single eye cable sock, but for when offset positioning is required. Excellent for pulling slack out of lines that have been pulled. May also be used for removing underground cables when end of cable is available.

Slingco Part No.	Range		Lattice Weave	Lattice Length		Overall Length		Approx. Break Load	
	in	mm		in	mm	in	mm	lb	kg
<b>OFFSET EYE STANDARD SOCK - GALVANISED</b>									
ZCS1860	0.25 - 0.50	6 - 13	Single	9	230	12	305	1,680	760
ZCS1861	0.50 - 0.75	13 - 19	Single	14	355	17	430	2,240	1015
ZCS1862	0.75 - 1.00	19 - 25	Single	16	405	20	510	5,600	2540
ZCS1863	1.00 - 1.50	25 - 38	Single	18	455	24	610	7,837	3555
ZCS1864	1.50 - 2.00	38 - 50	Double	21	535	29	735	11,200	5080
ZCS1865	2.00 - 2.50	50 - 63	Double	24	610	34	865	11,200	5080
ZCS1866	2.50 - 3.50	63 - 89	Double	27	685	39	990	13,440	6095
ZCS1867	3.50 - 4.50	89 - 115	Double	27	685	39	990	15,680	7110
ZCS1974	4.50 - 5.50	115 - 140	Double	27	685	39	990	15,680	7110
<b>OFFSET EYE STANDARD SOCK - 316 STAINLESS STEEL</b>									
ZCS1986	0.25 - 0.50	6 - 13	Single	9	230	12	305	1,344	610
ZCS1987	0.50 - 0.75	13 - 19	Single	14	355	17	430	1,792	810
ZCS1988	0.75 - 1.00	19 - 25	Single	16	405	20	510	4,480	2,030
ZCS1989	1.00 - 1.50	25 - 38	Single	18	455	24	610	6,272	2,845
ZCS1990	1.50 - 2.00	38 - 50	Double	21	535	29	735	8,960	4065
ZCS1991	2.00 - 2.50	50 - 63	Double	24	610	34	865	8,960	4,065
ZCS1992	2.50 - 3.50	63 - 89	Double	27	685	39	990	10,752	4,875
ZCS1993	3.50 - 4.50	89 - 115	Double	27	685	39	990	12,544	5,690
ZCS1994	4.50 - 5.50	115 - 140	Double	27	685	39	990	12,544	5,690

- The break loads and lengths shown above are as a guide only – for exact calculations please refer to data sheets which can be obtained from [sales@slingcoaustralia.com.au](mailto:sales@slingcoaustralia.com.au)
- For socks/stockings above 140mm diameter please contact – [sales@slingcoaustralia.com.au](mailto:sales@slingcoaustralia.com.au)

## DE TYPE - DOUBLE EYE SOCK



Ideal for pulling light to medium loads; the main advantage over the single eye cable sock is the cable being pulled can be passed through the sock, several cable socks can be used to support over a calculated distance.

Slingco Part No.	Range		Lattice Weave	Lattice Length		Overall Length		Approx. Break Load	
	in	mm		in	mm	in	mm	lb	kg
<b>DOUBLE EYE STANDARD SOCK - GALVANISED</b>									
ZCS0305	0.25 - 0.50	6 - 13	Single	9	230	12	305	1,680	760
ZCS0306	0.50 - 0.75	13 - 19	Single	14	355	17	430	2,240	1,015
ZCS0307	0.75 - 1.00	19 - 25	Single	16	405	20	510	5,600	2,540
ZCS0308	1.00 - 1.50	25 - 38	Single	18	455	24	610	7,840	3,555
ZCS0309	1.50 - 2.00	38 - 50	Double	21	535	29	735	11,200	5,080
ZCS0310	2.00 - 2.50	50 - 63	Double	24	610	34	865	11,200	5,080
ZCS0311	2.50 - 3.50	63 - 89	Double	27	685	39	990	13,440	6,095
ZCS0312	3.50 - 4.50	89 - 115	Double	27	685	39	990	15,680	7,110
ZCS0878	4.50 - 5.50	115 - 140	Double	27	685	39	990	15,680	7,110
<b>DOUBLE EYE STANDARD SOCK - 316 STAINLESS STEEL</b>									
ZCS0823	0.25 - 0.50	6 - 13	Single	9	230	12	305	1,344	610
ZCS1007	0.50 - 0.75	13 - 19	Single	14	355	17	430	1,792	810
ZCS0931	0.75 - 1.00	19 - 25	Single	16	405	20	510	4,480	2,030
ZCS1265	1.00 - 1.50	25 - 38	Single	18	455	24	610	6,272	2,845
ZCS1252	1.50 - 2.00	38 - 50	Double	21	535	29	735	8,960	4,065
ZCS0319	2.00 - 2.50	50 - 63	Double	24	610	34	865	8,960	4,065
ZCS0213	2.50 - 3.50	63 - 89	Double	27	685	39	990	10,752	4,875
ZCS0332	3.50 - 4.50	89 - 115	Double	27	685	39	990	12,544	5,690
ZCS1982	4.50 - 5.50	115 - 140	Double	27	685	39	990	12,544	5,690

- The break loads and lengths shown above are as a guide only – for exact calculations please refer to data sheets which can be obtained from [sales@slingcoaustralia.com.au](mailto:sales@slingcoaustralia.com.au)
- For socks/stockings above 140mm diameter please contact – [sales@slingcoaustralia.com.au](mailto:sales@slingcoaustralia.com.au)

LU TYPE - LACE UP SOCK



Ideal for pulling light to medium loads; the LU Type is fitted to the cable being pulled by stitching it together, like a football. Mainly used where a 'typical' cable sock can't be fitted over a connector at the end of a cable. For use in pulling when the end is not accessible. The LU Type is wrapped around the cable, then closed with the wire lace provided. See Lace Up instructions on page XX.

- The break loads and lengths shown above are as a guide only – for exact calculations please refer to data sheets which can be obtained from [sales@slingcoaustralia.com.au](mailto:sales@slingcoaustralia.com.au)
- For socks/stockings above 140mm diameter please contact – [sales@slingcoaustralia.com.au](mailto:sales@slingcoaustralia.com.au)

Slingco Part No.	Range		Lattice Weave	Lattice Length		Overall Length		Approx. Break Load	
	in	mm		in	mm	in	mm	lb	kg
<b>LACE UP STANDARD SOCK - GALVANISED</b>									
ZCS1157	0.25 - 0.50	6 - 13	Single	8	230	17	305	1,680	760
ZCS0872	0.50 - 0.75	13 - 19	Single	17	355	22	430	2,240	1,015
ZCS0871	0.75 - 1.00	19 - 25	Single	14.5	405	19	510	5,600	2,540
ZCS0328	1.00 - 1.50	25 - 38	Single	15	455	22	610	6,000	2,722
ZCS0329	1.50 - 2.00	38 - 50	Double	27	535	36	735	11,200	5,080
ZCS0330	2.00 - 2.50	50 - 63	Double	26	610	36	865	11,200	5,080
ZCS0331	2.50 - 3.50	63 - 89	Double	22	685	31	990	13,440	6,095
ZCS0853	3.50 - 4.50	89 - 115	Double	27	685	39	990	15,680	7,110
ZCS1109	4.50 - 5.50	115 - 140	Double	27	685	39	990	15,680	7,110
ZCS3584	5.31 - 6.30	135 - 160	Double	39	1,000	63	1,600	38,080	17,000
ZCS3585	6.33 - 7.48	161 - 190	Double	59	1,500	83	2,100	38,080	17,000
<b>LACE UP STANDARD SOCK - 316 STAINLESS STEEL</b>									
ZCS1983	0.25 - 0.50	6 - 13	Single	9	230	12	305	1,344	610
ZCS1796	0.50 - 0.75	13 - 19	Single	14	355	17	430	1,792	810
ZCS1789	0.75 - 1.00	19 - 25	Single	16	405	20	510	4,480	2,030
ZCS1797	1.00 - 1.50	25 - 38	Single	18	455	24	610	6,272	2,845
ZCS1984	1.50 - 2.00	38 - 50	Double	21	535	29	735	8,960	4,065
ZCS2466	2.00 - 2.50	50 - 63	Double	24	610	34	865	8,960	4,065
ZCS0816	2.50 - 3.50	63 - 89	Double	27	685	39	990	10,752	4,875
ZCS5094	2.75 - 3.44	69 - 87	Multiple	55	1,390	81	2,063	40,000	17,857
ZCS1356	3.50 - 4.50	89 - 115	Double	27	685	39	990	12,544	5,690
ZCS2832	3.50 - 4.50	89 - 115	Triple	27	685	39	990	14,012	6,300
ZCS1355	4.50 - 5.50	115 - 140	Double	27	685	39	990	12,544	5,690

OPEN ENDED SOCK



Ideal for joining two cables to form a continuous loop. Typical application: replacement of lift cables, where the old cable would be attached to the new one, and the cable then fed around with ease. Also used to temporarily splice cable and conductor where torsion forces are NOT an issue. Torsion should be released prior to splicing. Where torsion is present a swivel and two socks should be used.

Slingco Part No.	Range		Lattice Weave	Lattice Length		Approx. Break Load	
	in	mm		in	mm	lb	kg
<b>OPEN ENDED STANDARD SOCK - GALVANISED</b>							
ZCS0313	0.25 - 0.50	6 - 13	Single	15	380	1,680	760
ZCS6420	0.25 - 0.50	6 - 13	Double	22	559	3,500	1,588
ZCS0314	0.50 - 0.75	13 - 19	Single	24	610	2,240	1,015
ZCS6421	0.50 - 0.75	13 - 19	Double	30	762	4,500	2,040
ZCS6425	0.50 - 0.75	13 - 19	Multi	70	1,779	7,500	3,400
ZCS0315	0.75 - 1.00	19 - 25	Single	28	710	5,600	2,540
ZCS6422	0.75 - 1.25	19 - 32	Double	30	762	8,000	3,630
ZCS6426	0.75 - 1.00	19 - 25	Multi	80	2,032	11,800	5,352
ZCS0316	1.00 - 1.50	25 - 38	Single	32	815	7,840	3,555
ZCS6423	1.00 - 1.50	25 - 38	Double	36	915	10,000	4,537
ZCS6427	1.00 - 1.50	25 - 38	Multi	90	2,285	20,000	9,070
ZCS0317	1.50 - 2.00	38 - 50	Double	36	915	11,200	5,080
ZCS0318	2.00 - 2.50	50 - 63	Double	42	1,065	11,200	5,080
ZCS1158	2.50 - 3.50	63 - 89	Double	48	1,220	13,440	6,095
ZCS1159	3.50 - 4.50	89 - 115	Double	54	1,370	15,680	7,110
ZCS6424	4.25 - 4.88	108 - 124	Triple	55	1,400	19,500	8,847
ZCS1975	4.50 - 5.50	115 - 140	Double	54	1,370	15,680	7,110
<b>OPEN ENDED STANDARD SOCK - 316 STAINLESS STEEL</b>							
ZCS1995	0.25 - 0.50	6 - 13	Single	15	380	1,344	610
ZCS1996	0.50 - 0.75	13 - 19	Single	24	610	1,792	810
ZCS1997	0.75 - 1.00	19 - 25	Single	28	710	4,480	2,030
ZCS1998	1.00 - 1.50	25 - 38	Single	32	815	6,272	2,845
ZCS1999	1.50 - 2.00	38 - 50	Double	36	915	8,960	4,065
ZCS2000	2.00 - 2.50	50 - 63	Double	42	1,065	8,960	4,065
ZCS2001	2.50 - 3.50	63 - 89	Double	48	1,220	10,752	4,875
ZCS2002	3.50 - 4.50	89 - 115	Double	54	1,370	12,544	5,690
ZCS2003	4.50 - 5.50	115 - 140	Double	54	1,370	12,544	5,690
ZCS11923	6.50 - 7.50	165 - 191	Double	120	3,048	12,544	5,690

## FIBRE OPTIC CABLE SOCK



Slingco Part No.	Range		Lattice Length		Overall Length		Approx. Break Load	
	in	mm	in	mm	in	mm	lb	kg
ZCS2008	0.11 - 0.23	2.5 - 5.6	11	265	18	455	950	431
ZCS2009	0.21 - 0.36	5.3 - 9.2	15	370	22	560	1,650	748
ZCS2010	0.32 - 0.49	8.1 - 12.5	19	470	27	690	2,200	998
ZCS2011	0.42 - 0.62	10.7 - 15.8	20	515	29	735	2,750	1,247
ZCS2012	0.53 - 0.75	13.5 - 19.1	23	595	32	815	3,700	1,678
ZCS2013	0.64 - 0.88	16.3 - 22.4	25	645	34	865	4,250	1,928
ZCS2014	0.75 - 1.00	19.1 - 25.5	27	720	37	940	4,250	1,928

Dual weave design from galvanised wire rope. Used for the installation of fibre optic cables for either overhead or underground applications. Made of galvanised steel.

## SPLICING SOCK - ROTATING SWIVEL LINK



Slingco Rotating Swivel Link Socks are perfect for stringing replacement wire and cable on equipment and in drilling or rigging systems. Not recommended for use in overhead stringing applications. Use the existing cable as a pull wire to string the replacement cable. These socks are available with differently sized socks for each side. Call for assistance in selecting the proper sock. Link opens for easy installation and adjustment. Made of galvanised steel.

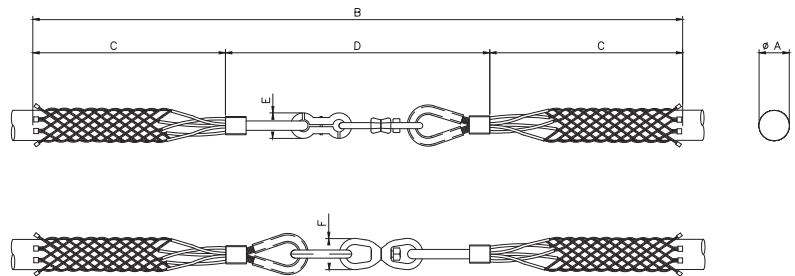

Slingco Part No.	Range		Ø A Nominal		B Length		C Length		D Length		E Length		F Length		Approx. Break Load	
	in	mm	in	mm	in	mm	in	mm	in	mm	in	mm	in	mm	lb	kg
ZCS3493	0.25 - 0.50	6 - 13	0.37	9.5	100.0	2,542	44.3	1,127	11.3	288	0.87	22	1.25	32	2,400	1,089
ZCS3494	0.50 - 1.00	13 - 25	0.75	19	103.2	2,621	45.7	1,160	11.8	301	1.38	35	1.25	32	3,526	1,599
ZCS3495	1.00 - 1.50	25 - 38	1.26	32	104.5	2,654	45.7	1,160	13.1	334	1.61	41	1.61	41	5,070	2,300
ZCS3496	1.50 - 2.00	38 - 51	1.75	44.5	105.2	2,673	45.7	1,160	13.9	353	1.61	41	2.0	51	8,000	3,629
ZCS3497	2.00 - 2.75	51 - 70	2.38	60.5	105.2	2,673	45.7	1,160	13.9	353	1.61	41	2.0	51	10,000	4,537
ZCS3498	2.75 - 3.50	70 - 90	3.15	80	105.2	2,673	45.7	1,160	13.9	353	1.61	41	2.0	51	10,000	4,537
ZCS3499	3.50 - 4.25	89 - 108	3.88	98.5	108.4	2,753	45.7	1,200	13.9	353	1.61	41	2.0	51	10,000	4,537

## SLINGCO AUSTRALIA IS OPEN FOR BUSINESS! SERVING THE ENTIRE ASIA-PACIFIC REGION

As part of our major global expansion plans, we're now serving the whole of Australia, New Zealand and our trusted distribution partners across Asia-Pacific from our new sales and distribution centre in Melbourne, VIC, Australia.

Hundreds of lines available ex-stock!



Visit [slingcoaustralia.com.au](http://slingcoaustralia.com.au), email [sales@slingcoaustralia.com.au](mailto:sales@slingcoaustralia.com.au) or call +61 3 8840 6556 to find out more

## SLINGCO NON-METALLIC ARAMID CABLE SOCKS

### FOR PULLING CABLE IN MANY INDUSTRIAL & COMMERCIAL PROJECTS



#### Slingco's Non-Metallic Aramid Cable Sock Features:

- Break loads similar to steel cable socks
- Lightweight
- No more frayed sock wires
- UV Resistant and strong enough to last in salt water, pollutants, and underground
- We can create custom socks to meet your specifications

Slingco's line of Non-Metallic Aramid Cable Socks are ideal for use in fiber optic cable installation operations, offshore applications, or for a multitude of uses in the utilities industry.

These socks are made of a high-strength, non-metallic aramid fiber, with UV protective coating, and now feature an improved weight to break ratio. They are suitable for pulling both single cable and multiple cable bundles.

Thanks to the non-metallic material, these socks are easy to work with even without gloves. The woven mesh material also offers

a non-metallic, non-conductive alternative to steel socks.

We have many different styles of Non-Metallic Aramid Cable Socks for your project, such as Single Eye, Double Eye, Offset Eye, Lace Up, Mining Socks, and our new Single Eye Double Weave Socks made of ultra flex aramid material. We can also work with you to customize an Aramid Cable Sock to match any particular project specifications.

Call your Slingco Account Manager today and they will help you select the right sock for your project!

#### NS TYPE - SINGLE EYE ARAMID CABLE SOCK



Single Eye Single Weave Non-Metallic Cable Sock



Single Eye Double Weave Non-Metallic Cable Sock

Slingco Part No.	Range		Lattice Length		Approx. Break Load	
	in	mm	in	mm	lb	kg
<b>SINGLE EYE SINGLE WEAVE NON-METALLIC CABLE SOCK</b>						
ZCS1040	0.38 - 0.75	10 - 20	21	552	2,460	1,115
ZCS1022	0.75 - 1.25	20 - 30	21	523	3,580	1,620
ZCS2923	1.00 - 1.50	25 - 38	23	573	3,580	1,620
ZCS1041	1.25 - 1.50	30 - 40	25	642	4,920	2,230
ZCS1042	1.50 - 2.00	40 - 50	19	485	5,820	2,640
<b>SINGLE EYE DOUBLE WEAVE NON-METALLIC CABLE SOCK</b>						
ZCS1023	1.25 - 1.50	30 - 40	25	642	9,860	4,470
ZCS1024	1.50 - 2.00	40 - 50	21	523	11,880	5,390
ZCS1179	2.00 - 2.50	50 - 65	25	636	15,900	7,210
ZCS1180	2.50 - 3.00	65 - 80	36	908	15,900	7,210
ZCS1181	3.00 - 4.00	80 - 100	40	1,029	15,900	7,210
ZCS4079	3.94 - 4.92	100 - 125	125	3,168	15,900	7,212
<b>SINGLE EYE DOUBLE WEAVE HIGH STRENGTH NON-METALLIC SOCK</b>						
ZCS13054	4.00 - 5.00	102 - 127	118	2,992	45,500	20,638

Slingco Part No.	Range		Colour code	Approx. Break Load	
	in	mm		lb	kg
<b>ULTRA-FLEX SINGLE EYE DOUBLE WEAVE NON-METALLIC CABLE SOCK</b>					
ZCS09336	0.63 - 0.75	16 - 19	Yellow	5,000	2,267
ZCS09337	0.75 - 1.00	19 - 25	Red	6,000	2,721
ZCS09338	1.00 - 1.25	25 - 32	Blue	6,000	2,721
ZCS09339	1.25 - 1.50	32 - 38	White	6,000	2,721

## ND TYPE - DOUBLE EYE ARAMID CABLE SOCK



Slingco Part No.	Range		Lattice Length		Approx. Break Load	
	in	mm	in	mm	lb	kg
<b>DOUBLE EYE SINGLE WEAVE NON-METALLIC SOCK</b>						
ZCS1148	0.38 - 0.75	10 - 20	22	552	2,460	1,115
ZCS1176	0.75 - 1.25	20 - 30	21	523	3,580	1,620
ZCS2922	1.00 - 1.50	25 - 38	23	573	3,580	1,620
ZCS1177	1.25 - 1.50	30 - 40	25	642	4,920	2,230
ZCS1178	1.50 - 2.00	40 - 50	19	487	5,820	2,640
<b>DOUBLE EYE DOUBLE WEAVE NON-METALLIC SOCK</b>						
ZCS1182	1.25 - 1.50	30 - 40	25	642	9,860	4,472
ZCS1183	1.50 - 2.00	40 - 50	26	667	11,880	5,389
ZCS1184	2.00 - 2.50	50 - 65	25	636	15,900	7,212
ZCS1185	2.50 - 3.00	65 - 80	30	762	15,900	7,212
ZCS1186	3.00 - 4.00	80 - 100	32	800	15,900	7,212
ZCS3813	4.00 - 5.00	102 - 127	61	1,540	15,900	7,212

## NO TYPE - OFFSET EYE ARAMID CABLE SOCK



Slingco Part No.	Range		Lattice Length		Approx. Break Load	
	in	mm	in	mm	lb	kg
<b>SINGLE OFFSET EYE SINGLE WEAVE NON-METALLIC SOCK</b>						
ZCS2810	0.38 - 0.75	10 - 20	21	525	2,460	1,115
ZCS2811	0.75 - 1.25	20 - 30	21	525	3,580	1,620
ZCS2921	1.00 - 1.50	25 - 38	23	573	3,580	1,620
ZCS2812	1.25 - 1.50	30 - 40	25	642	4,920	2,230
ZCS2813	1.50 - 2.00	40 - 50	21	525	5,820	2,640
<b>SINGLE OFFSET EYE DOUBLE WEAVE NON-METALLIC SOCK</b>						
ZCS09342	0.5 - 1.00	13 - 25	39	990	8,093	3,671
ZCS2814	1.25 - 1.50	30 - 38	34	864	9,860	4,470
ZCS2815	1.50 - 2.00	38 - 50	25	635	11,880	5,390
ZCS2816	2.00 - 2.50	50 - 65	25	635	15,900	7,210
ZCS2817	2.50 - 3.00	65 - 80	26	660	15,900	7,210
ZCS2818	3.00 - 4.00	80 - 100	34	864	15,900	7,210
<b>SINGLE OFFSET EYE EXTENDED EYE 12" NON-METALLIC SOCK</b>						
ZCS7053	0.50 - 0.63	13 - 16	24	600	800	363
ZCS7054	0.63 - 0.74	16 - 19	24	600	1,000	454
ZCS7055	0.75 - 1.00	19 - 25	24	600	1,200	544
ZCS7056	1.00 - 1.25	25 - 32	24	600	1,200	544
<b>SINGLE OFFSET EYE LACE UP NON-METALLIC CABLE SOCK</b>						
ZCS09323	0.63 - 1.00	65 - 76	59	1,499	13,000	5,896
ZCS10476	3.00 - 3.50	76 - 102	30	762	5,000	2,268
<b>DOUBLE OFFSET EYE NON-METALLIC CABLE SOCK</b>						
ZCS8176	2.50 - 3.00	65 - 76	39	991	8,000	3,629
ZCS09959	2.50 - 3.00	65 - 76	36	914	9,000	4,082
ZCS6823	3.00 - 4.00	76 - 102	33	838	9,000	4,082



**STANDARD DUTY HOSE RESTRAINT SOCKS - DOUBLE EYE**



Slingco offer a range of safety restraining socks and whipchecks designed to prevent whipping in the event of a pressurised hose becoming detached from its fitting.

Made from the highest grade galvanised steel and 316 stainless steel wire, and colour coded for range identification, our socks are designed for various plant-critical applications across a wide range of commercial industries. Suitable for restraining all types of high pressure hoses such as water and air hoses, hydraulic hoses, concrete pump and delivery hoses as well as supporting electrical cabling within critical applications within mining, automation and other industrial sectors.

The socks are woven in such a way that the lattice or weave is uniform throughout its length, ensuring even load protection around the hose. This helps with any adverse abrasion to the hose and prevents displacement in the event of rupture. Available for 5mm to 200mm diameter hoses.



Slingco Part No.	Sock material	Thimble Eye	Thimble Size	Weave	Range		Eye length		Lattice/Weave		Overall length		Break load			Colour Code
					mm	in	mm	in	mm	in	mm	in	kg	lb	kN	
ZCS14350	Galv	SS	6	Double	6-14	0.24-0.55	90	4	330	13	420	17	1600	3527	16	White
ZCS14351	Galv	SS	6	Double	14-20	0.55-0.80	90	4	352	14	442	17	2000	4409	20	White
ZCS14352	Galv	SS	6	Double	20-30	0.80-1.25	115	5	574	23	689	27	2500	5512	25	White
ZCS14353	Galv	SS	8	Double	30-40	1.25-1.50	165	6	810	32	975	38	4300	9480	42	Brown
ZCS14354	Galv	SS	8	Double	40-50	1.50-2.00	185	7	893	35	1078	42	6200	13669	61	Orange
ZCS14355	Galv	SS	10	Double	50-60	2.00-2.40	230	9	1215	48	1445	57	8100	17857	79	Yellow
ZCS14356	Galv	SS	10	Double	60-70	2.40-2.75	240	9	1224	48	1464	58	8100	17857	79	Blue
ZCS14357	Galv	SS	10	Double	70-90	2.75-3.50	260	10	1295	51	1555	61	8100	17857	79	Red
ZCS14358	Galv	SS	14	Double	90-110	3.50-4.30	280	11	1468	58	1748	69	10500	23148	103	Green
ZCS14359	Galv	SS	14	Double	110-130	4.30-5.00	350	14	1551	61	1901	75	12500	27558	123	Black
ZCS14360	Galv	SS	16	Double	120-150	4.70-5.90	400	16	1582	62	1982	78	16000	35274	157	Grey
ZCS14361	Galv	SS	16	Double	140-180	5.50-7.00	450	18	1533	60	1983	78	20000	44092	196	Light Blue
ZCS14362	SS	SS	6	Double	6-14	0.24-0.55	90	4	330	13	420	17	1280	2822	13	White
ZCS14363	SS	SS	6	Double	14-20	0.55-0.80	90	4	352	14	442	17	1600	3527	16	White
ZCS14364	SS	SS	6	Double	20-30	0.80-1.25	115	5	574	23	689	27	2000	4409	20	White
ZCS14365	SS	SS	8	Double	30-40	1.25-1.50	165	6	810	32	975	38	3440	7584	34	Brown
ZCS14366	SS	SS	8	Double	40-50	1.50-2.00	185	7	893	35	1078	42	4960	10935	49	Orange
ZCS14367	SS	SS	10	Double	50-60	2.00-2.40	230	9	1215	48	1445	57	6480	14286	64	Yellow
ZCS14368	SS	SS	10	Double	60-70	2.40-2.75	240	9	1224	48	1464	58	6480	14286	64	Blue
ZCS14369	SS	SS	10	Double	70-90	2.75-3.50	260	10	1295	51	1555	61	6480	14286	64	Red
ZCS14370	SS	SS	14	Double	90-110	3.50-4.30	280	11	1468	58	1748	69	8400	18519	82	Green

## HEAVY DUTY HOSE RESTRAINT SOCKS - DOUBLE EYE



Our heavy duty range of hose restraint socks can be used in areas where high break loading are required, mainly within highly critical environments. Available in our standard double format we also offer a range using a multi-weave option.

The socks are woven in such a way that the lattice or weave is uniform throughout its length ensuring even load protection around the hose. This helps with any adverse abrasion to the hose and prevents displacement in the event of rupture.

Available for - 10mm to 200mm diameter hoses.



Slingco Part No.	Eye Type	Range		Lattice Length		Lattice Weave	Approx. Break Load	
		in	mm	in	mm		lb	kg
<b>DOUBLE THIMBLE EYE - GALVANISED STEEL</b>								
ZCS5363	Thimble eye	1.0 - 1.5	25 - 38	26	660	Double	11,000	4,911
ZCS5364	Thimble eye	1.5 - 2.5	38 - 63	40	1,016	Double	20,000	8,928
ZCS5365	Thimble eye	2.5 - 3.5	63 - 89	42	1,067	Double	22,000	9,821
ZCS5366	Thimble eye	3.5 - 4.5	89 - 114	44	1,118	Double	27,000	12,053
ZCS5367	Thimble eye	4.5 - 5.5	114 - 140	48	1,219	Double	31,000	13,839
ZCS6012	Thimble eye	5.5 - 7.0	140 - 180	60	1,524	Double	50,000	22,685
<b>DOUBLE THIMBLE EYE - 316 STAINLESS STEEL</b>								
ZCS5650	Thimble eye	1.0 - 1.5	25 - 38	26	660	Double	7,700	3,437
ZCS5651	Thimble eye	1.5 - 2.5	38 - 63	40	1,016	Double	14,000	6,250
ZCS5652	Thimble eye	2.5 - 3.5	63 - 89	42	1,067	Double	15,400	6,874
ZCS5653	Thimble eye	3.5 - 4.5	89 - 114	44	1,118	Double	18,900	8,437
ZCS5654	Thimble eye	4.5 - 5.5	114 - 140	48	1,219	Double	21,700	9,687
ZCS6000	Thimble eye	5.5 - 7.0	140 - 180	60	1,524	Double	35,000	15,880
<b>DOUBLE THIMBLE EYE - GALVANISED STEEL (LONG)</b>								
ZCS3146	Thimble	0.59-0.79	15-20	49	1,250	Single	2,730	1,240
ZCS3148	Thimble	0.79-1.18	20-30	49	1,250	Double	4,380	1,990
ZCS3149	Thimble	1.18-1.57	20-30	49	1,250	Single	5,620	2,550
ZCS3150	Thimble	1.18-1.57	30-40	49	1,250	Double	6,740	3,060
ZCS3151	Thimble	1.57-1.97	40-50	59	1,500	Double	13,060	5,930
ZCS3152	Thimble	1.97-2.36	50-60	59	1,500	Double	14,610	6,630
ZCS3153	Thimble	2.36-2.76	60-70	59	1,500	Double	17,160	7,790
ZCS3154	Thimble	2.76-3.54	70-90	59	1,500	Double	17,870	8,110
ZCS3155	Thimble	3.54-4.33	90-110	59	1,500	Double	26,070	11,830
ZCS3156	Thimble	4.33-5.12	110-130	59	1,500	Double	26,070	11,830
ZCS3157	Thimble	4.72-5.91	120-150	59	1,500	Double	28,100	12,750
ZCS3158	Thimble	5.51-7.09	140-180	59	1,500	Double	28,100	12,750
<b>DOUBLE EYE MULTIWEAVE - MAX STRENGTH - 316 STAINLESS STEEL</b>								
ZCS3995	Thimble eye	1.14 - 1.57	29 - 40	50	1,270	Double	35,000	15,625
ZCS3295	Flex eye	2.75 - 3.44	70 - 87	58	1,460	Multiple	49,000	22,230
ZCS3254	Flex eye	3.00 - 3.50	76 - 89	58	1,460	Multiple	39,200	17,785
ZCS6004	Flex eye	3.50 - 4.75	89 - 120	58	1,460	Multiple	50,000	22,320



## WHIPCHECK



The strong steel cable prevents hose-whip accidents in the event of hose or coupling failure. Easily fitted spring loaded loops grip the hose firmly.

Slingco Part No.	Material	Wire mm	Range		Length		Max WP PSI	WLL kN
			in	mm	in	mm		
<b>WHIPCHECK - HOSE TO HOSE</b>								
ZWR11530	Stainless Steel	3	0.5 - 1.25	13 - 32	22	550	200	5.7
ZWR11534	Galvanised	3	0.5 - 1.25	13 - 32	22	550	200	5.7
ZWR11535	Galvanised	6	1.5 - 3	38 - 76	42	1,060	200	21.2
ZWR14271	Galvanised	3.5	0.375 - 1.25	10 - 32	22	550	200	6.5
ZWR14272	Galvanised	6	1.25 - 2	32 - 50	33	850	200	17.6
ZWR14273	Galvanised	6	2.5 - 4	63 - 100	45	1,150	200	17.6

**SUBSEA MARINE SOCKS  
FOR ARRAY, EXPORT,  
UMBILICAL AND SUBSEA  
CABLE INSTALLATIONS**

High-volume project capacity, quick availability, full test reports and certification, and over 40 years experience



We offer extensive ranges of marine cable socks and hose restraint cable socks for applications including on-shore and off-shore cable installation, support of cables inside wind turbines and general cable management. We have also developed a range of cable pulling socks for use in the installation of inter-array and export cables from offshore wind farm installations.

- Single Eye, Double Eye, Lace Up Cable Socks
- Max Break Load 10Te – 90Te+
- Galvanised, Stainless and Aramid Socks
- Complete range to suit Cable OD range 10mm-350mm+
- Test reports & certification
- Large project delivery
- Quick availability
- 40+ years' experience
- Award winning company





Slingco Part No. FLEX Eye	Slingco Part No. THIMBLE Eye	Range		Lattice Length		Approx. Break Load		Lattice Material
		in	mm	in	mm	lb	kg	
<b>SINGLE EYE</b>								
ZCS12740-2M	ZCS12740-THI-2M	3.5 - 5	90 - 125	78.75	2,000	110,230	50,000	Galv.
ZCS12740-2.5M	ZCS740-THI-2.5M	3.5 - 5	90 - 125	98.5	2,500	110,230	50,000	Galv.
ZCS12740-3M	ZCS12740-THI-3M	3.5 - 5	90 - 125	118	3,000	110,230	50,000	Galv.
ZCS3525	ZCS3525-THI	4 - 5	102 - 127	78.75	2,005	110,310	45,500	Galv.
ZCS12741-2.5M	ZCS12741-THI-2.5M	4.3 - 5.7	110 - 145	98.5	2,500	121,250	55,000	Galv.
ZCS12741-3M	ZCS12741-THI-3M	4.3 - 5.7	110 - 145	118	3,000	121,250	55,000	Galv.
ZCS3526	ZCS3526-THI	5 - 6	127 - 152	71.7	1,821	104,720	47,500	Galv.
ZCS12742	ZCS12742-THI	5.1 - 6.7	130 - 172	118	3,000	143,300	65,000	Galv.
ZCS3527	ZCS3527-THI	6 - 8	152 - 203	66	1,678	110,230	50,000	Galv.
ZCS12743	ZCS12743-THI	6.1 - 8.25	155 - 210	118	3,000	154,300	70,000	Galv.
ZCS12744	ZCS12744-THI	7.67 - 9.8	195 - 250	118	3,000	187,393	85,000	Galv.
ZCS3528	ZCS3528-THI	8 - 10	203 - 255	80.5	2,047	138,900	63,000	Galv.
ZCS12745	ZCS12745-THI	9.25 - 11.22	235 - 285	118	3,000	198,400	90,000	Galv.
ZCS3529	ZCS3529-THI	10 - 12	255 - 305	76.5	1,945	138,900	63,000	Galv.
ZCS3530	ZCS3530-THI	12 - 14	305 - 355	97	2,460	138,000	62,600	Galv.
<b>DOUBLE EYE</b>								
ZCS12754-2M	ZCS12754-THI-2M	3.5 - 5	90 - 125	78.75	2,000	121,250	55,000	Galv.
ZCS12754-2.5M	ZCS12754-THI-2.5M	3.5 - 5	90 - 125	98.5	2,500	121,250	55,000	Galv.
ZCS12754-3M	ZCS12754-THI-3M	3.5 - 5	90 - 125	118	3,000	121,250	55,000	Galv.
ZCS3535	ZCS3535-THI	4 - 5	102 - 127	78.75	2,005	124,560	56,500	Galv.
ZCS12755-2.5M	ZCS12755-THI-2.5M	4.3 - 5.7	110 - 145	98.5	2,500	132,275	60,000	Galv.
ZCS12755-3M	ZCS12755-THI-3M	4.3 - 5.7	110 - 145	118	3,000	132,275	60,000	Galv.
ZCS3536	ZCS3536-THI	5 - 6	127 - 152	71.7	1,821	124,560	56,500	Galv.
ZCS12756	ZCS12756-THI	5.1 - 6.7	130 - 172	118	3,000	165,350	75,000	Galv.
ZCS3537	ZCS3537-THI	6 - 8	152 - 203	64.3	1,633	126,765	57,500	Galv.
ZCS12757	ZCS12757-THI	6.1 - 8.25	155 - 210	118	3,000	176,370	80,000	Galv.
ZCS12758	ZCS12758-THI	7.67 - 9.8	195 - 250	118	3,000	198,400	90,000	Galv.
ZCS3538	ZCS3538-THI	8 - 10	203 - 255	80.5	2,047	156,528	71,000	Galv.
ZCS12759	ZCS12759-THI	9.25 - 11.22	235 - 285	118	3,000	209,439	95,000	Galv.
ZCS3539	ZCS3539-THI	10 - 12	255 - 305	76.5	1,945	156,528	71,000	Galv.
ZCS3540	ZCS3540-THI	12 - 14	305 - 355	97	2,460	156,528	71,000	Galv.
ZCS3540-3M	ZCS3540-THI-3M	12 - 14	305 - 355	118	3,000	156,528	71,000	Galv.
<b>LACE UP</b>								
ZCS12760	ZCS12760-THI	3.5 - 5	90 - 125	78.75	2,000	110,230	50,000	Galv
ZCS3545	ZCS3545-THI	4 - 5	102 - 127	78.75	2,005	105,822	48,000	Galv
ZCS12761	ZCS12761-THI	4.3 - 5.7	110 - 145	98.5	2,500	110,230	50,000	Galv
ZCS3546	ZCS3546-THI	5 - 6	127 - 152	71.7	1,821	105,822	48,000	Galv
ZCS12762	ZCS12762-THI	5.1 - 6.7	130 - 172	118	3,000	154,300	70,000	Galv
ZCS3547	ZCS3547-THI	6 - 8	152 - 203	66	1,678	105,822	48,000	Galv
ZCS12763	ZCS12763-THI	6.1 - 8.25	155 - 210	118	3,000	154,300	70,000	Galv
ZCS12764	ZCS12764-THI	7.67 - 9.8	195 - 250	118	3,000	198,000	90,000	Galv
ZCS3548		8 - 10	203 - 255	80.5	2,047	132,277	60,000	Galv
	ZCS3548-THI	8 - 10	203 - 255	98.5	2,500	132,277	60,000	Galv
ZCS12765	ZCS12765-THI	9.25 - 11.22	235 - 285	118	3,000	198,000	90,000	Galv
ZCS3549		10 - 12	255 - 305	76.5	1,945	132,277	60,000	Galv
	ZCS3549-THI	10 - 12	255 - 305	98.5	2,500	132,277	60,000	Galv
ZCS3550	ZCS3550-THI	12 - 14	305 - 355	118.35	3,006	132,277	60,000	Galv



**LINE PULLING SWIVELS**



LINE PULLING SWIVEL  
STANDARD ENDS

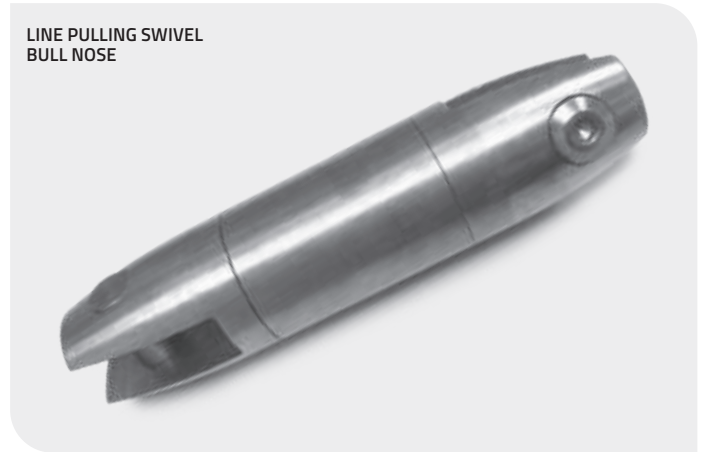

LINE PULLING SWIVEL  
BULL NOSE

Swivels are designed for use in stringing high tension wires for electrical transmission and distribution. They are important in pulling when the lines develop torsion during the installation. This torsion must be released. Use of a swivel will release torque and prevent it from reaching dangerous levels, which can cause damage to the cable or sock.

Slingco also offers a 'bull nose' style swivel designed for underground and overhead applications.

All swivels are stringently quality tested and inspected to ensure optimum performance and reliability.

**LINE PULLING SWIVEL – STANDARD ENDS**

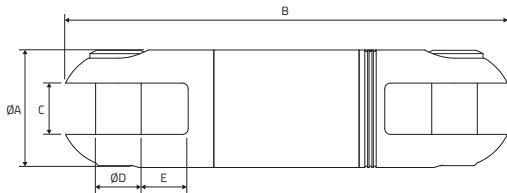

**LINE PULLING SWIVEL – BULL NOSE**

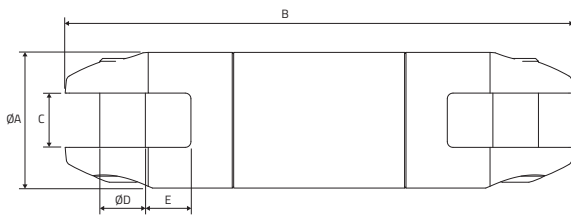

Slingco Part No.	Safe working load lb (kN)		Ø A in (mm)	B Length in (mm)	C Slot width in (mm)	D Pin Ø in (mm)	Ø E Recess in (mm)	Weight lb (kg)
	3:1	5:1						
<b>LINE PULLING SWIVEL – STANDARD ENDS</b>								
ZSW2091	2,250 (10)	1,350 (6)	0.87 (22)	3.37 (85.6)	0.39 (10)	0.31 (8)	0.39 (10)	0.43 (0.19)
ZSW2092	3,500 (15.5)	2,100 (9.3)	0.98 (25)	3.98 (101.1)	0.43 (11)	0.39 (10)	0.43 (11)	0.56 (0.25)
ZSW2093	5,000 (22)	3,000 (13.2)	1.26 (32)	4.96 (126)	0.55 (14)	0.39 (10)	0.55 (14)	1.13 (0.51)
ZSW2094	7,000 (31.1)	4,200 (18.7)	1.38 (35)	5.22 (132.7)	0.55 (14)	0.49 (12.5)	0.54 (13.8)	1.44 (0.65)
ZSW2096	10,000 (44.5)	6,000 (26.7)	1.62 (41.25)	6.11 (155.1)	0.71 (18)	0.63 (16)	0.65 (16.5)	2.35 (1.07)
ZSW2097	15,000 (66)	9,000 (39.6)	2.09 (53)	7.34 (186.4)	0.79 (20)	0.71 (18)	0.83 (21)	4.59 (2.08)
<b>LINE PULLING SWIVEL – BULL NOSE</b>								
ZSW2649	4,000 (17.8)	2,400 (10.7)	1.26 (32)	4.74 (120.5)	0.61 (15.5)	0.37 (9.5)	0.52 (13.25)	1.01 (0.46)
ZSW2929	8,000 (35.5)	4,800 (21.4)	1.50 (38)	5.38 (136.6)	0.63 (16)	0.43 (11)	0.61 (15.5)	1.75 (0.80)
ZSW6122	10,000 (44.5)	6,000 (26.7)	1.87 (47.6)	7.02 (178.3)	0.75 (19.05)	0.63 (16)	0.63 (16)	3.72 (1.69)
ZSW6123	16,000 (71.2)	9,600 (42.7)	2.44 (62)	10.15 (257.7)	1.00 (25.4)	0.87 (22)	1.12 (28.5)	9.19 (4.17)
ZSW2857	30,000 (134)	18,000 (80)	2.50 (63.5)	11.13 (282.6)	1.00 (25.4)	0.87 (22.2)	1.13 (28.6)	10.44 (4.74)

- The break loads and lengths shown above are as a guide only – for exact calculations please refer to data sheets which can be obtained from [sales@slingcoaustralia.com.au](mailto:sales@slingcoaustralia.com.au)
- For socks/stockings above 140mm diameter please contact – [sales@slingcoaustralia.com.au](mailto:sales@slingcoaustralia.com.au)

Swivel or Connector Model	ZSW2091	ZSW2092	ZSW2093	ZSW2094	ZSW2096 ZSW6122	ZSW2097	ZSW2929	ZSW2649	ZSW2857	ZSW6123	ZSW6554	ZSW6555	ZSW6556	ZSW6557 ZSW6558 ZSW6559 ZSW6560
Replacement Pin (HEX)	SWI2858	SWI2810	SWI2340	SWI2341	SWI2343	SWI2344	SWI2801	SWI2648	SWI2748	SWI5184	SWI2859	SWI2339	SWI5309	SWI5310

**SAFETY NOTE:** All Slingco Line Pulling Swivels are designed for straight line pulling and will not support side loads as would be encountered traveling over a bull wheel. Swivel selection should be based on pulling line diameter, sock size, opening dimensions, pin sizes, working load, and sheave groove diameter. Swivels are not designed for general lifting.

## DIRECTIONAL DRILLING SWIVELS



Slingco Directional Drilling Swivels are designed to counter rotational forces caused by boring equipment used in underground pulling and drilling applications. Grease nipple included for removal of dirt and contaminants. Made of carbon steel and zinc passivated for durability. Hex pins. Quality tested and inspected to ensure optimum reliability and performance.



Slingco Part No	Safe Working Load (3:1)		A		Ø B		C		D		Ø E		F	
	lb	kN	in	mm	in	mm	in	mm	in	mm	in	mm	in	mm
ZSW11133	8,500	37.8	7.24	183.8	1.62	41.2	0.63	16.0	1.60	40.6	0.53	13.4	0.55	13.9
ZSW11134	10,000	44.4	8.32	211.3	2.00	50.8	0.75	19.0	1.79	45.0	0.59	14.9	0.75	19.0

- The break loads and lengths shown above are as a guide only – for exact calculations please refer to data sheets which can be obtained from [sales@slingcoaustralia.com.au](mailto:sales@slingcoaustralia.com.au)
- For socks/stockings above 140mm diameter please contact – [sales@slingcoaustralia.com.au](mailto:sales@slingcoaustralia.com.au)

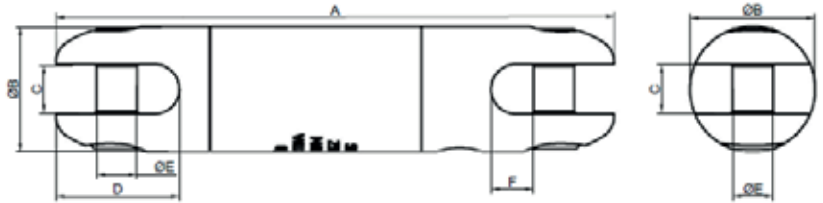

## C CONNECTORS



Use to connect rope, swivels and other objects.

Slingco Part No.	No.	Model	A	B	C	D	E	d Pin dia	Working load	Weight
			mm	mm	mm	mm	mm	mm	KN	kg
ZSW7314	1	SLU-1	36	68	18	14	29	10	10	0.2
ZSW7315	2	SLU-3	37	76	20	17	31	12	30	0.23
ZSW7316	3	SLU-5	50	96	23	19	42	18	50	0.6
ZSW7317	4	SLU-8	56	110	28	22	50	20	80	0.8
ZSW7318	5	SLU-10	59	126	30	26	54	22	100	1.2
ZSW7319	6	SLU-13	61	134	32	27	56	24	130	1.3
ZSW7320	7	SLU-25	80	178	44	35	72	30	250	3.0

- The break loads and lengths shown above are as a guide only – for exact calculations please refer to data sheets which can be obtained from [sales@slingcoaustralia.com.au](mailto:sales@slingcoaustralia.com.au)
- For socks/stockings above 140mm diameter please contact – [sales@slingcoaustralia.com.au](mailto:sales@slingcoaustralia.com.au)

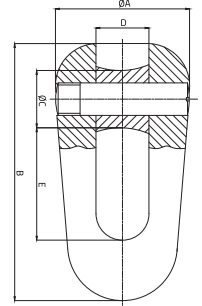

## CONNECTORS: 90°, ROPE TO ROPE, ROPE TO SWIVEL



Use to connect rope, swivels and other objects. With high strength pins and smooth rollers you can safely connect rope without fear of fraying or damage. Use the convenient 90° connectors to link wire and other non-rope items. Connectors have high strength hex pins. The Rope to Rope connector has two rollers to protect rope from becoming frayed.

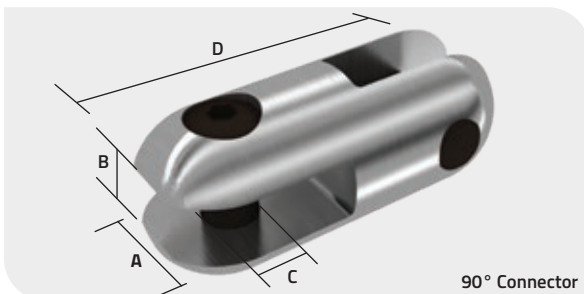

### 90° Connector

Slingco Part No.	Safe working load		A		B		C		D		Weight	
	lb	kg	in	mm	in	mm	in	mm	in	mm	lb	kg
ZSW6554	2,500	1,134	0.875	22	0.375	9.6	0.313	8	2.175	54	0.17	0.08
ZSW6555	5,000	2,240	1.25	31.8	0.53	13.5	0.406	10	2.875	73	0.46	0.21
ZSW6556	9,000	4,030	1.5	38.1	0.594	15	0.5	12.5	3.375	86	0.73	0.33
ZSW6557	15,000	6,800	2	50.8	0.781	20	0.688	18	4.563	116	2	0.91

### Rope to Rope Connector

Slingco Part No.	Safe working load	Max rope dia.	A	B	C	D	Weight							
	lb	kg	in	mm	in	mm	lb							
ZSW6558	15,000	6,800	7/8	22.2	2	50.8	15/16	24	11/16	18	5 1/2	140	2.7	1.23

### Rope to Swivel Connector

Slingco Part No.	Safe working load		Max rope dia.	A		B		C		D		E		F		Weight		
	lb	kg		in	mm	in	mm	in	mm	in	mm	in	mm	in	mm			
ZSW6559	7,000	3,170	0.875	22.2	2	50.8	0.938	24	0.688	18	5.313	135	0.5	12.7	0.531	13.5	2.09	0.95
ZSW6560	15,000	6,800	0.875	22.2	2	50.8	0.938	24	0.688	18	5.313	137	0.656	16.7	0.75	18	2.54	1.15

Safe working load based upon 3:1 factor of safety.

- The break loads and lengths shown above are as a guide only – for exact calculations please refer to data sheets which can be obtained from [sales@slingcoaustralia.com.au](mailto:sales@slingcoaustralia.com.au)
- For socks/stockings above 140mm diameter please contact – [sales@slingcoaustralia.com.au](mailto:sales@slingcoaustralia.com.au)

BRIDGE TYPE CABLE LAYING ROLLER



Made of steel with zinc plating for general purpose cable installation work in trenches or over rough surfaces. They are suitable for power, telecoms and utility installations, and can bridge existing cables or conduit in trenches or ducts.

The Compact Cable Roller is for use in narrow trenches and/or in confined areas. Contact Slingco if you have custom roller needs.

Bridge Type Cable Roller

Slingco Part No.	Base Footprint in (mm)	Height to top of roller in (mm)	Handle height in (mm)
ZGP2395	12 x 9.5 (305 x 240)	7.125 (180)	10 (255)

Compact Bridge Type Cable Laying Roller

Slingco Part No.	Base Footprint in (mm)	Height in (mm)	Max Cable Diameter in (mm)	Weight lb (kg)
ZGP8270	10.83 x 5.9 (275 x 150)	7 (180)	3.54 (90)	5.5 (2.5)

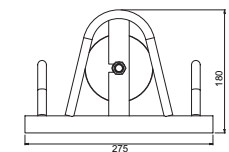
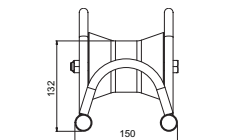
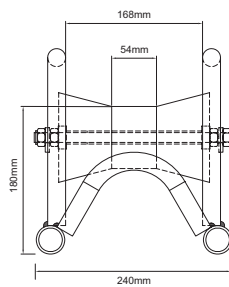

\* Drawing measurements in mm

EDGE MOUNT MANHOLE LEAD-IN CABLE ROLLER (HEAVY DUTY)



The manhole cable roller leads the cable from the drum into the jointbox/manhole or the winch bond out of the manhole.

- Heavy duty tubular steel construction
- Suitable for cables up to 130mm
- 3 x 110mm diameter steel roller\* fitted with sealed precision roller bearings
- Zinc plated
- Weight: 10 Kg

\* The Diablo Rollers can be substituted with a heavy gauge 89mm tubular Steel Roller fitted with oil impregnated maintenance free bushes for use with the heavier cables.

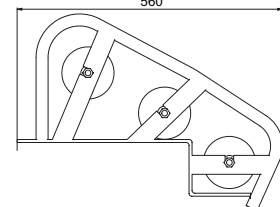
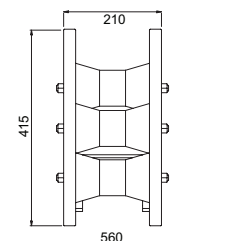

Slingco Part No.	Base Footprint in (mm)	Height in (mm)
ZGP8209	22 x 8.25 (560 x 210)	16.34 (415)

EDGE MOUNT MANHOLE LEAD-IN CABLE ROLLER (LIGHT DUTY)



The manhole cable roller leads the cable from the drum into the jointbox/manhole or the winch bond out of the manhole. The roller has 2 hooks for location on the edge of the manhole.

- Heavy steel section construction
- 76mm diameter aluminium roller\*
- Fitted with oil-impregnated maintenance-free bushes
- Sealed precision roller bearings
- Zinc plated or powder coated finish
- Weight 3Kg

\*The aluminium roller can be substituted with a solid steel roller when using wire winch bond thus preventing damage.

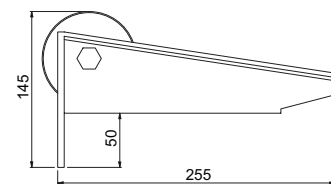
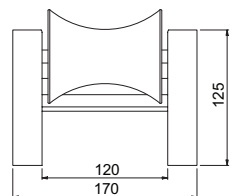

Slingco Part No.	Base Footprint in (mm)	Height in (mm)
ZGP8210	10 x 6.7 (255 x 170)	5.7 (145)

## HEAVY DUTY 214MM STRAIGHT LINE CABLE ROLLER

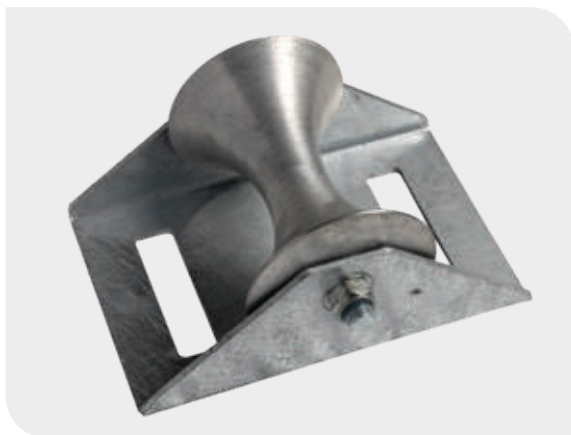

The diablo is machined with a 107mm radius giving a maximum capacity of 214mm diameter.

- Heavy duty folded frame straight line roller
- Aluminium diablo roller with 78mm radius
- Sealed roller bearing and 20mm shaft
- Galvanised finish
- Weight : 7Kg

Slingco Part No.	Base Footprint in (mm)	Height in (mm)
ZGP8268	11.81 x 7.87 (300 x 200)	6.1 (155)

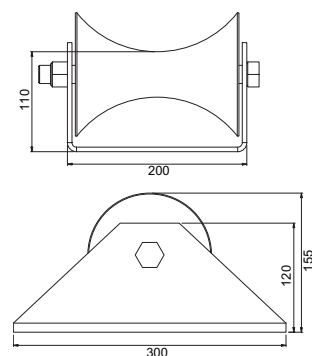

## HEAVY DUTY TRIPLE CORNER CABLE ROLLER



This is a heavy duty corner cable roller for use in most cable laying applications. They can be used singularly or linked together using link pins to form a full bend. All products in the bend roller range have the same link points to facilitate various bend/roller configurations.

- Heavy duty corner roller made from tubular sections
- 3 x 110mm diameter large waisted steel rollers\*
- Sealed roller bearing fitted
- Zinc plated finish
- Universal link pin mount positions
- Weight 8.5Kg

\* The diablo rollers can be substituted with a heavy gauge 89mm tubular steel roller fitted with oil impregnated maintenance free bushes.

Slingco Part No.	Base Footprint in (mm)	Height in (mm)
ZGP8269	16.4 x 12.6 (410 x 320)	11.61 (295)

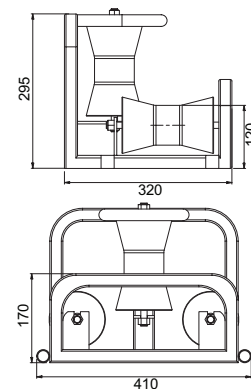

## CABLE DRUM ROTATOR

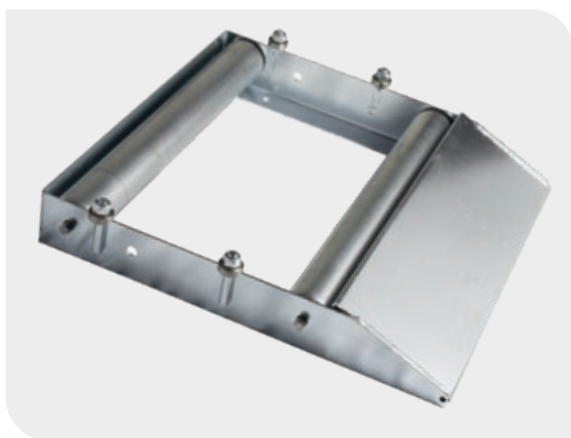

This is a compact light weight Cable Drum Rotator. Drums are simply rolled up the ramp on to the adjustable rollers to allow it to spin freely.

- Pressed steel construction
- Ideal for where space is limited.
- 60 mm diameter zinc plated rollers
- Sealed roller bearings fitted
- Spring loaded shafts for easy replacement/adjustment
- Capacity 200 Kg
- Max / min drum size 800 / 300 mm
- Drum Width 450 mm
- Zinc plated finish
- Weight: 10.5 Kg

Slingco Part No.	Base Footprint in (mm)	Height in (mm)	Max Capacity lb (kg)
ZGP8267	19.68 x 20.66 (500 x 525)	4.72 (120)	440 (200)

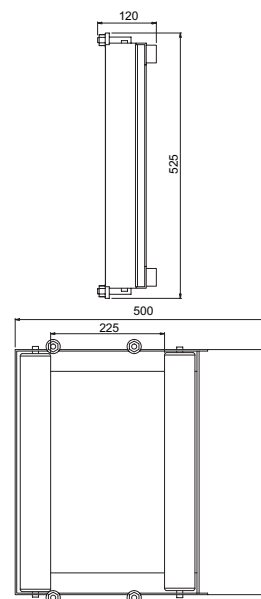

## TOOLS, BUCKLES AND BANDS FOR QUICK AND EFFICIENT BANDING OF CABLE SOCKS, HOSES AND MORE

Slingco Banding Tools deliver a fast and easy way to install banding clamps. Designed for fast and efficient installation of steel bands for cable socks, hoses and many other applications, their drop-forged construction and comfortable design makes them quick and easy to use and guarantee a long and useful tool life.

We offer three different tool options, with bands and buckles available for each (order separately). See opposite for the bands and buckles suited to each tool type.

In addition to our range of steel bands available from stock we can also manufacture custom sizes if required. Please call with your requirements.

### Slingco Fast Banding Tool



#### WITH PRE-LOOPED BANDS FOR QUICKLY SECURING SOCKS AND OTHER SIMPLE BANDING APPLICATIONS

Our Fast Banding Tool uses pre-looped punch-style bands for quick and secure banding of cable socks, hoses and other cylindrical items.

### FAST BANDING: PRE-LOOPED BANDS FOR QUICKLY



CPC2875

### Slingco Light Duty Banding Tool



#### FOR UTILITY POLE AND OTHER LIGHT DUTY POLE BANDING APPLICATIONS

Featuring a built-in cutter with PVC coated handle for comfort, and a sliding block assembly with spring loaded lever. Operates on band widths 3/8" to 3/4" and thicknesses up to 0.030".

### LIGHT DUTY BANDING: UTILITY POLE AND OTHER



CPC8748

### Slingco Heavy Duty Banding Tool



#### FOR UTILITY POLE AND OTHER HEAVY DUTY BANDING APPLICATIONS

Featuring a built-in cutter and a sliding block assembly. Operates on band widths 3/4", 1", and 1-1/4" and thickness of 0.044".

### HEAVY DUTY BANDING: UTILITY POLE AND OTHER



CPC8780

Note: Slingco recommends double banding the ends of cable socks.

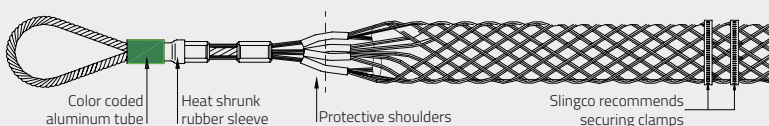

## SECURING SOCKS AND OTHER SIMPLE BANDING APPLICATIONS



Use pre-looped punch style bands to quickly and securely band cable socks, hoses or other cylindrical items.

The bands are pre-looped through the buckle to slide over the end of the item being banded. Just tighten the band using the Slingco Punch Banding Tool then, when the band is tight, just punch the head of the tool and snip off the extra banding. Simple!

The sizes opposite refer to the inner loop diameter of the band. Select the size that will comfortably fit over the item being banded.

Open End Band – non pre-looped 201 SS 5/8" wide band with attached buckle. Includes punch style buckle. Use as single loop for larger diameter or double looped for smaller diameters and added strength. Maximum diameter for single or double loops is listed.

Banding tool					
Slingco Part No.	Description				
CPC2875	Standard punch-style banding tool.				
Bands Pre-Looped					
Slingco Part No.	Width mm (in)	Thickness mm (in)	Loop diameter mm (in)	Pack quantity	
CPC2876	9.5 (3/8)	0.64 (0.025)	20.6 (13/16)	100/box	
CPC2880	15.9 (5/8)	0.76 (0.030)	25.4 (1)	100/box	
CPC2879	15.9 (5/8)	0.76 (0.030)	38.1 (1.5)	100/box	
CPC2878	15.9 (5/8)	0.76 (0.030)	50.8 (2.0)	100/box	
CPC2877	15.9 (5/8)	0.76 (0.030)	63.5 (2.5)	50/box	
CPC8532	15.9 (5/8)	0.76 (0.030)	76.2 (3.0)	50/box	
Open End Band – 201 SS					
Slingco Part No.	Width mm (in)	Thickness mm (in)	Length mm (in)	Loop diameter	Pack quantity
CPC08596	15.9 (5/8)	0.76 (0.030)	609 (24)	152.4mm (6") Single Wrap 76.2mm (3") Double Wrap	50/box

## LIGHT DUTY POLE BANDING APPLICATIONS



Use Slingco 3/4" wide 201 Stainless Steel, or the 1/2" wide 316 Stainless Steel, banding system to secure cables and other items to Utility poles, Light stands or other structures. The Light Duty Banding Tool allows you to easily tighten and secure any length band loop.

Slingco offers rolls of 3/4" and 1/2" wide banding material in 100 foot lengths. These 100 foot band rolls come in two convenient packages – standard stack-and-store cardboard packaging, or an easy to carry red plastic tote for the 3/4" and a blue plastic tote for the 1/2".

The buckles used to secure these bands are made of 201 Stainless Steel and designed for 3/4" width bands, and 316 Stainless Steel designed for 1/2" bands.



Banding tool					
Slingco Part No.	Description				
CPC8748	Operates on band widths 3/8" to 3/4" and thickness up to 0.030". Tool has a built in cutter with PVC coated handle for comfort and sliding block assembly with spring loaded lever.				
Bands					
Slingco Part No.	Width mm (in)	Thickness mm (in)	Avg break strength kg (lb)	Pack quantity	Weight kg (lb)
CPC8743	19 (3/4)	0.76 (0.030)	1,021 (2,250)	30.48m (100') roll - Cardboard Box	3.49 (7.7)
CPC8744	19 (3/4)	0.76 (0.030)	1,021 (2,250)	30.48m (100') roll - Red Plastic Tote	3.49 (7.7)
CPC08325	12.7 (1/2)	0.76 (0.030)	544 (1,200)	30.48m (100') roll - Cardboard Box	2.31 (5.1)
CPC08326	12.7 (1/2)	0.76 (0.030)	544 (1,200)	30.48m (100') roll - Blue Plastic Tote	2.68 (5.9)
Buckles					
Slingco Part No.	Width mm (in)	Pack quantity		Weight kg (lb)	
CPC8746	19 (3/4)	100/Box		1.68 (3.7)	
CPC08327	12.7 (1/2)	100/Box		1.13 (2.5)	

## HEAVY DUTY BANDING APPLICATIONS



Use the Slingco 1-1/4" 201 Stainless Steel Banding system to secure cables and other items to structures and poles where extra strength hold is required. The Heavy Duty Banding Tool allows you to easily tighten and secure any length band loop.

Perfect for use with concrete utility poles. The extra width of this band provides stronger tensile strength than the 3/4" band as well as a wider holding surface. Useful in many application environments including Utility, Marine and manufacturing where securely attaching cables, hoses or tubes onto a cylindrical object is needed. 100 ft. band roll comes in easy to stack and store cardboard box.

Giant buckles are made of 201 Stainless Steel and designed for use with 1-1/4" wide bands.

Banding tool					
Slingco Part No.	Description				
CPC8780	Operates on bands widths 19mm (0.75"), 25.4mm (1"), and 31.75mm (1.25") and thickness of 0.11mm (0.044"). Featuring a built-in cutter and a sliding block assembly.				
Bands					
Slingco Part No.	Width mm (in)	Thickness mm (in)	Average break strength kg (lb)	Pack quantity	Weight kg (lb)
CPC8745	31.75 (1.25)	0.11 (0.044)	2,495 (5,500)	30.48m (100') roll in CARDBOARD BOX PACKAGING	7.8 (17.2)
Buckles					
Slingco Part No.	Width mm (in)	Pack quantity		Weight kg (lb)	
CPC8747	31.75 (1.25)	25/Box		1.45 (3.2)	

- The break loads and lengths shown above are as a guide only – for exact calculations please refer to data sheets which can be obtained from [sales@slingcoaustralia.com.au](mailto:sales@slingcoaustralia.com.au)
- For socks/stockings above 140mm diameter please contact – [sales@slingcoaustralia.com.au](mailto:sales@slingcoaustralia.com.au)

**60 TON HYDRAULIC CRIMPING TOOL**

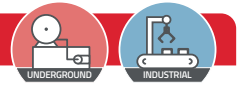

Slingco's Hydraulic Crimping Tools are designed to crimp sleeves and lugs on ACSR and ACAR transmission & distribution cables using dies that meet the standards of the utility industry. Our crimping tools are ideal for use in constructing substations and transmission lines.

The Single-Acting Crimping Tool uses hydraulic pressure to advance the ram into position, and an internal spring to return the ram to the original position. The Double-Acting Crimping Tool advances and returns the ram using hydraulic pressure alone, eliminating the possibility of the ram sticking or becoming jammed.

Our Hydraulic Crimping Tools come in a steel carrying case, and are lightweight and portable. Our crimping tools accept Slingco S60 Dies, or any shell-type dies used with Alcoa or Burndy 60-ton crimping tools.

- Accepts Slingco, Burndy L and Alcoa 6000 Series dies
- Steel Carrying Case Includes Ground Stand
- Lifting eye for hoist work
- For Crimping ACSR and ACAR transmission and distribution cables

Slingco Part No.	Crimping Force	Operating Pressure	Action	Tool Weight		Oil Required
				lb	kg	
TCR7003	60 Tons	10,000 psi (700 bar)	Single-Action	47	21.32	308 cc
TCR7018	60 Tons	10,000 psi (700 bar)	Double-Action	51	23.13	314 cc

**Replacement Dies for 60-Ton Hydraulic Crimping Tools**



Slingco Part No.	Slingco Ref.	Alcoa Equivalent
TCR7067	S60-10SH	6010SH
TCR7068	S60-12SH	6012SH
TCR7069	S60-14SH	6014SH
TCR7070	S60-16SH	6016SH
TCR7071	S60-18SH	6018SH
TCR7072	S60-20SH	6020SH
TCR7073	S60-24SH	6024SH
TCR7074	S60-27SH	6027SH
TCR7075	S60-30SH	6030SH
TCR7076	S60-34SH	6034SH
TCR7077	S60-36SH	6036SH
TCR7078	S60-38SH	6038SH

Slingco Part No.	Slingco Ref.	Alcoa Equivalent
TCR7083	S60-40AH	6040AH
TCR7084	S60-44AH	6044AH
TCR7085	S60-48AH	6048AH
TCR7086	S60-52AH	6052AH
TCR7087	S60-56AH	6056AH
TCR7088	S60-60CD	6008CD
TCR7089	S60-64CD	6009CD
TCR7090	S60-68CD	6010CD
TCR7091	S60-72CD	6011CD
TCR7092	S60-76CD	6012CD
TCR7093	S60-80CD	6013CD
TCR7094	S60-84CD	6014CD
TCR7095	S60-88CD	6015CD
TCR7096	S60-92CD	6016CD
TCR7097	S60-96CD	6017CD

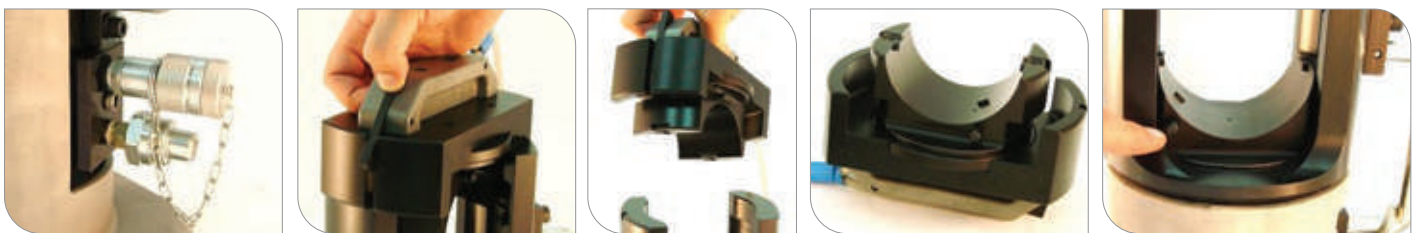

# 100 TON HYDRAULIC CRIMPING TOOL



Slingco's 100 Ton Hydraulic Crimping Tool is ideal for use in constructing substations and transmission lines. This tool is designed to crimp sleeves and lugs on ACSR and ACAR transmission cables using dies that meet the standards of the utility industry.

- Accepts U or shell type dies
- Steel Carrying Case
- Large handles for easy carrying
- Easy die installation

The TCR0849 comes in a single-action configuration but can be converted to double-action functionality.

### Crimping Range

- Copper: Up to 2.5" OD Sleeve
- Aluminium: Up to 3" OD Sleeve
- Steel: Up to 1.25" OD Sleeve

Comes with steel carrying case.

Slingco Part No.	Crimping Force	Operating Pressure	Action	Tool Weight		Oil Required
				lb	kg	
TCR08490	100 Tons	10,000 psi (700 bar)	Single-Action	78	35.38	422 cc

### Replacement Dies for 100-Ton Hydraulic Crimping Tools



Slingco Part No.	Slingco Ref.	Alcoa Equivalent	Slingco Part No.	Slingco Ref.	Alcoa Equivalent
TCR08544	S100-10SH	10010SH	TCR08563	S100-42AH	10042AH
TCR08545	S100-12SH	10012SH	TCR08564	S100-44AH	10044AH
TCR08546	S100-14SH	10014SH	TCR08565	S100-46AH	10046AH
TCR08547	S100-16SH	10016SH	TCR08566	S100-48AH	10048AH
TCR08548	S100-18SH	10018SH	TCR08567	S100-07CD	10007CD
TCR08549	S100-20SH	10020SH	TCR08568	S100-08CD	10008CD
TCR08550	S100-74SH	10074SH	TCR08569	S100-09CD	10009CD
TCR08551	S100-75SH	10075SH	TCR08570	S100-10CD	10010CD
TCR08552	S100-20AH	10020AH	TCR08571	S100-11CD	10011CD
TCR08553	S100-24AH	10024AH	TCR08572	S100-12CD	10012CD
TCR08554	S100-27AH	10027AH	TCR08573	S100-13CD	10013CD
TCR08555	S100-30AH	10030AH	TCR08574	S100-14CD	10014CD
TCR08556	S100-34AH	10034AH	TCR08575	S100-15CD	10015CD
TCR08557	S100-36AH	10036AH	TCR08576	S100-16CD	10016CD
TCR08558	S100-38AH	10038AH	TCR08577	S100-17CD	10017CD
TCR08559	S100-40AH	10040AH	TCR08578	S100-18CD	10018CD
TCR08560	S100-74AH	10074AH	TCR08579	S100-19CD	10019CD
TCR08561	S100-75AH	10075AH	TCR08580	S100-20CD	10020CD
TCR08562	S100-76AH	10076AH			



**MECHANICAL CRIMPING TOOLS**



Slingco's Mechanical Crimping Tools have been created to complete the variety of utility distribution service connections that need to be made on the line, pole, and home. Our crimping tools have been designed to provide reliable crimps installing full-tension or non-tension connectors.

Slingco's Mechanical Crimping Tool's 'D3' groove allows 'W' style die inserts for installing taps, splices, and terminal connectors. The 'W' die inserts lock securely and easily into place with the positive lock, spring-loaded die buttons. Slingco also offers a Mechanical Crimping Tool that accepts Kearney type dies.

Our Mechanical Crimping Tools also have ergonomic handles for comfortable use and maximum leverage when making critical connections.

Slingco Part No.	Tool Type	Crimp Force		Length		Weight	
		lb	kg	in	mm	lb	kg
TCR7002	O&D	9,000	4,082	25.75	65.4	7	3.175
TCR7004	BG&D	9,000	4,082	25.75	65.4	7	3.175
TCR08735	5/8 Nose Die & Kearney Seat (Accepts 'Kearney' type)	9,000	4,082	25.75	65.4	7	3.175

**Slingco W-Die Sets (D3 Insert)**

Slingco Part No.	Slingco Ref.	Burndy Equiv.
TCR7020	S6-K840	WK840
TCR7021	S6-BG	WBG
TCR7022	S6-O	WO
TCR7023	S6-247	W247
TCR7024	S6-249	W249
TCR7025	S6-161	W161
TCR7027	S6-163	W163
TCR7028	S6-164	W164
TCR7029	S6-165	W165
TCR7030	S6-166	W166
TCR7031	S6-167	W167
TCR7034	S6-237	W237
TCR7036	S6-239	W239
TCR7037	S6-241	W241
TCR7038	S6-243	W243
TCR7039	S6-245	W245
TCR7047	S6-C	WC
TCR7058	S6-25RT	W25RT
TCR7059	S6-26RT	W26RT

**Slingco O-Die Sets (Kearney Seat)**

Slingco Part No.	Slingco Ref.	Burndy Equiv.
TCR10117	O Die - 1/2	1/2
TCR10118	O Die - 1/4	1/4
TCR10119	O Die - 3/8	3/8
TCR10120	O Die - 5/8-1	5/8-1
TCR10121	O Die - 5/16	5/16
TCR10122	O Die - 9/16	9/16
TCR10123	O Die - 11/16	11/16
TCR10124	O Die - 19/32	19/32
TCR10125	O Die - 620	620
TCR10126	O Die - 635	635
TCR10127	O Die - 747	747
TCR10128	O Die - 781	781
TCR10129	O Die - 840	840
TCR10130	O Die - 845	845
TCR10131	O Die - B	B
TCR10132	O Die - 3/16	3/16
TCR10133	O Die - T	T
TCR10134	O Die - D	D
TCR10135	O Die - J	J
TCR10136	O Die - K	K
TCR10137	O Die - O	O
TCR10138	O Die - P	P
TCR10139	O Die - 737	737

**RATCHET CUTTERS (ACSR)**



The Slingco ACSR Ratchet Cutter is designed to cut hard cables cleanly and smoothly. The ratchet design provides leverage, increasing cutting force with each open and close of the handles. Makes cutting cable easier compared to manual cutters.

The handles surfaces are designed to allow a firm, secure grip. The ratcheting action makes these cutters easy to operate even in limited spaces with just moderate pressure.

Do not use on energized lines.

- For cutting ACSR cable
- Smooth ratchet operation
- Cuts up to 30 mm ACSR and other hard cable cleanly

Slingco Part No.	Description	For cutting	Length in (mm)	Weight lb (kg)
TCU09280	Hard Cable (ACSR) Ratchet Cutter	ACSR	30" (762 mm)	12 lb (5.44 kg)
TCU09281	CU - AL Ratchet Cutter	CU & AL	30" (762 mm)	12 lb (5.44 kg)

## REEL LIFTER



The Slingco Reel Lifter is a high capacity, compact unit that allows users in the utility construction industry to safely load, transport, and dispense wire and/or cable on-site. It is also used in many industrial applications to make moving and relocating reels in a warehouse easy. Now a task that normally used a team of three or four people can be done with just one, allowing the crew to operate more efficiently!

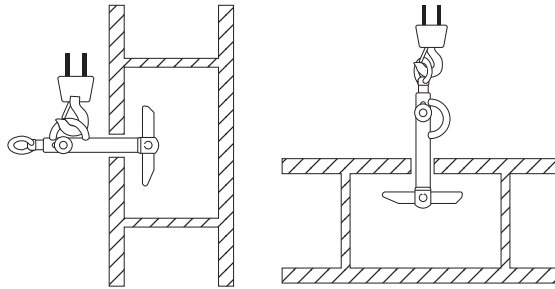

Makes handling large cable reels quick and easy, on-site or in warehouses.

- Rugged construction to lift and unroll reels
- Easy rotation to unroll cable
- Counterweighted bottom arm for easy insertion in reel
- Side lifting eye allows reels to be put into a rolling or non-rolling position
- Repair kits available

### Reel Lifter

Slingco Part No.	Arbor Hole Min.		Arbor Hole Max.		Capacity		Weight		Length	
	in	mm	in	mm	lb	kg	lb	kg	in	mm
ZLD08729	2	50.8	4	101.6	3,000	1360.78	6.50	2.95	16.125	409.6
ZLD09186	3	76.2	6	152.4	5,000	2267.96	14.50	6.58	21.125	536.6
ZLD10807	3	76.2	6	152.4	12,000	5443.11	32.5	14.74	30.5	774.7
<b>Reel Lifter Repair Kit</b>										
ZLD09708	1,360.78kg (3,000lb) factory repair kit with extension springs, cable assemblies and all necessary pins for replacement of the interior cable system. Suitable for ZLD08729.									
ZLD09707	2,267.96kg (5,000lb) factory repair kit with extension springs, cable assemblies and all necessary pins for replacement of the interior cable system. Suitable for ZLD09186.									

## HAND LINE TOOLS

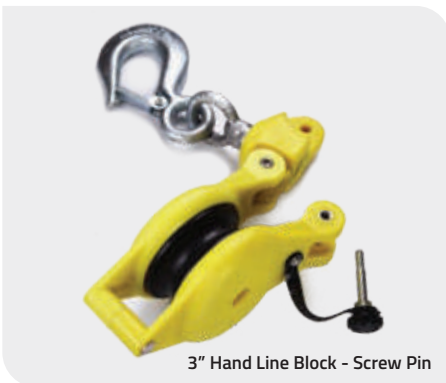

3" Hand Line Block - Screw Pin

Slingco's Hand Line Tools feature a 76.2mm (3") nylon fiberglass block, with a safe working load limit of 453.59 kg (1,000 lb), and a double locking snap with a safe working load limit of 2267.96 kg (5,000 lb).

Our 76.2mm (3") Hand Line Block's sheave can accommodate a 15.875 mm (0.625") diameter rope, and operates smoothly on the 12.7 mm (0.5") diameter axle and swivel bearings. The side opening feature allows quick access to remove the hand line.

The Hand Line Hook is made of manganese bronze, and is made for use with 12.7 mm (0.5") rope.

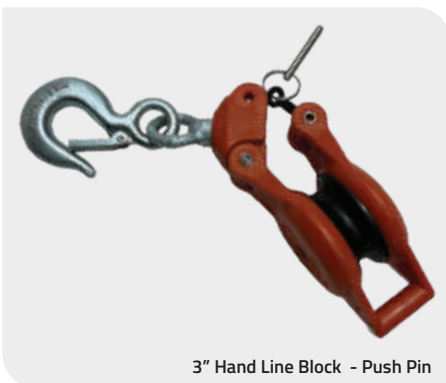

3" Hand Line Block - Push Pin

Slingco Part No.	Description	Working Load Limit	
		lb	kg
ZAB8725	3" Hand Line Block (Screw Pin)	1,000	453.59
ZAB8725-P	3" Hand Line Block (Push Pin)	1,000	453.59
HMI8556	Double Locking Snap	5,000	2,267.96
HMI6502	Hand Line Hook	272	123.38



Double Locking Snap Hook



Hand Line Hook

35KV JUMPER CLAMP



Slingco's Jumper Clamps are used as a part of jumper cable assemblies to bypass work areas when equipment is under repair or being upgraded. Jumper clamps are lightweight and impact resistant making them incredibly durable. We make inspection of the cable, ferrule, and clamp simple and easy via the transparent clamp body. The jaw of the Slingco Jumper Clamp and floating ring contact is made from a copper-based alloy.

Slingco Part No.	Main Line Range	Max. Continuous Amps	Threading	Length	Weight
ZSC09344	954 MCM (0.162 - 1.25)	400	5/8" - 11 threads per inch	11.5" (292mm)	2.5 lb (1.15 kg)
ZSC12110	477 MCM (0.162 - 0.9)	400	5/8" - 11 threads/inch	11.5" (292mm)	2.4 lb (1.09 kg)

*NOTE: Slingco Jumper Clamps are sold individually. Slingco Jumper Clamps meet ASTM F2321 standard.*

RUBBER BLANKET ACCESSORIES



Used to hold insulating blankets and other types of rubber coverups in place, Slingco Blanket Clamp Pins, Pole Clamps and Blanket Magnets are constructed of ultraviolet stabilized fiberglass reinforced polymer.

**BLANKET CLAMP PIN**

The Slingco Blanket Clamp Pin has extra holes in the center of the body and is used to grip conductors and prevent linehose from sliding. Holes have also been placed in the handles to enable attachment of warnings, tags, and/or flags. The handles of the pin are shaped to engage with the end ferrule of a clampstick (shotgun stick).

**POLE CLAMP**

The Slingco Pole Clamp is meant to eliminate the use of tie wraps, bungee cords, tapes or any other items that can cause damage to insulated rubber products.

With Slingco's unique tool handle lock system, the Pole Clamp can be set in an open position by engaging the handle lock. Once the product is in its intended location the lock can be released making installation easier.

**BLANKET MAGNET**

The Slingco Blanket Magnet is designed to fit through the eyelets of an insulated blanket. Afterwards, the magnet along with the blanket can be placed over energized areas of transformers, switchboards and substations. Can be placed and repositioned with hot line tools.



**Blanket Clamp Pin**

Slingco Part No.	Length		Jaw Opening		Weight		Note
	in	mm	in	mm	oz	g	
ZPE10962	9.5	241	5	127	5	141.5	
ZPE12136	9.5	241	5	127	5.4	153	with Hot Stick Clip

**Pole Clamp**

Slingco Part No.	Length		Width		Jaw Opening		Weight	
	in	mm	in	mm	in	mm	lb	kg
ZPE11399	20.25	514.4	8.25	203.2	13.5	342.9	1.7	0.77
ZPE11398	28	711.2	11.5	291.2	19.75	501.7	2.2	1.0

**Blanket Magnet**

Slingco Part No.	Height		Diameter		Weight		Magnet rating	
	in	mm	in	mm	lb	g	lb	kg
PPE10785	2.4	60.6	1.75	44.4	0.2	90.7	120	54.4

## POLE PULLER

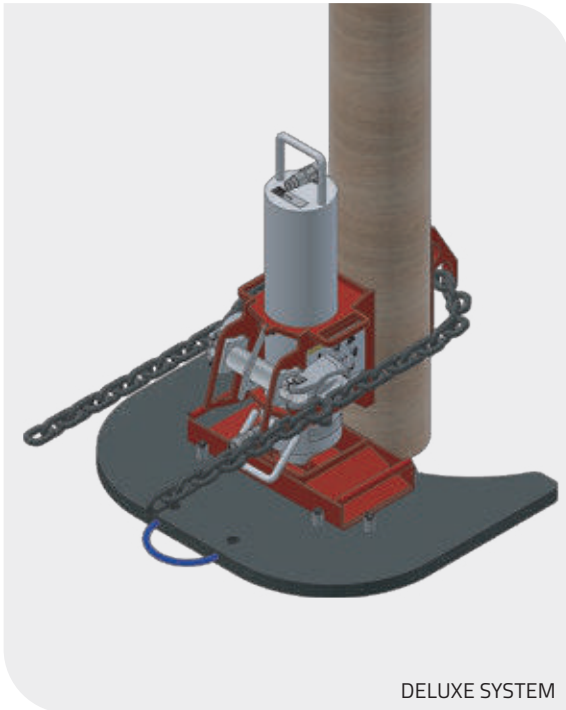

DELUXE SYSTEM

Slingco's pole puller is a must have to comply with today's safe working practices, reducing the potential for boom damage and greatly reducing the potential of personal injury.

The pole puller is easily assembled and disassembled. The standard pole puller system is composed of four pieces and the deluxe system six pieces. These configurations make the Slingco pole puller easy to handle and lighter weight than typical units on the market.

The Slingco Deluxe Pole Puller system includes the pole puller pad and back plate weldment. The pole puller pad has studs which keep the base plate in the optimum position when pulling poles. The back plate weldment has angled teeth to increase hold on the pole during extraction. Slingco's pole puller offers a low point of attachment making it easy to remove even broken or cut poles. Convenient handles on the pole puller body make inserting over cylinder easy and pinch-free.

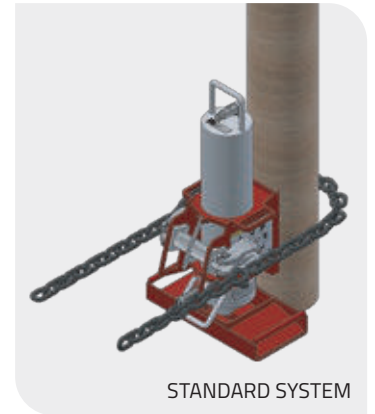

STANDARD SYSTEM

Slingco Part No.	Description	Max. Operating Pressure		Recommended Flow Rate		Lift at Max. Pressure		System Total Weight	
		PSI		GPM		lb	kg	lb	kg
TPE09386	Deluxe Pole Puller System	2,800		4 – 8		50,120	22,734	157	71.2
DELUXE Pole Puller System consists of: hydraulic cylinder*, chain, base weldment, swivel assembly PLUS back plate weldment, and pole puller pad. *hydraulic cylinder comes with flush face fittings installed.									
TPE10551	Standard Pole Puller System	2,800		4 – 8		50,120	22,734	128	58
STANDARD Pole Puller System consists of: hydraulic cylinder*, chain, base weldment, swivel assembly. *hydraulic cylinder comes with flush face fittings installed.									
TPE09378	Pole Puller Pad							23	10.43
TPE09367	Back Plate Weldment							6	2.72

## POLE STAND



Slingco's pole stand is lightweight and compact making it easy to place, remove, and store on your truck or jobsite. The support leg's swing-and-lock design make moving and storing the Slingco pole stand a breeze.

The pole stand positions the pole at an optimal height for easy and safe framing. The pole stand's capacity of 6,000 lb makes it capable of handling the majority of wood distribution poles. Its curved cradle allows for safe rotation of the pole for proper framing positioning.

The pole stand's high visibility and durability make it a proven choice for any work location or environment.

Slingco Part No.	Description	Capacity		Height		Width		Weight	
		lb	kg	in	cm	in	cm	lb	kg
TPE09682	Pole Stand	6,000	2,722	23.75	60.33	30	76.2	32	14.5



- Lightweight and compact
- Quick swing-and-lock legs
- Positions poles for safe and comfortable framing

DIRT TARPS



Slingco's range of heavy-duty, re-usable dirt tarps have been created with safety in mind. Keeping workers out of awkward, injury-prone positions is better for their long-term health and the company's bottom line. Dirt tarps have become a must-have product at utility construction sites. You can find Slingco Dirt Tarps being used at pole change-outs, transformer terminations, pedestals, as well as underground gas, telephone, and other underground utility applications.

In fact, with the ability to move crushed rock, sand, dirt, wet cement, dig spoils, and other contaminated soil, there are few reasons NOT to have a Slingco Dirt Tarp on the project!

Slingco Part No.	Tarp Dimensions		Maximum Capacity	
	ft	m	lb	kg
ZLD10015	10 x 10	3 x 3	5,000	2,267
ZLD10016	8 x 8	2.44 x 2.44	5,000	2,267
ZLD10793	7 x 7	2.13 x 2.13	4,000	1,814
ZLD10792	6 x 6	1.83 x 1.83	4,000	1,814

STAY WIRE DISPENSER



Slingco's Stay Wire Dispenser saves linemen time, effort, and keeps them safe. Efficiently dispense and take up excess stay wire from a permanently mounted source. Operation of the dispenser is kept smooth thanks to the high load sealed ball bearing. The Stay Wire Dispenser is constructed of high strength steel coated in a durable black and yellow finish to enable the unit to endure the harsh outdoor environment. Easy to operate release knobs allow for quick and easy loading and unloading.

- Handles Stay Wire OD up to 1/2"
- Permanently mounts to truck or other surface
- Smooth pay-out operation thanks to high load sealed bearings

Slingco Part No.	Max. Wire Size		Coil Width Capacity		Coil Diameter Range		Weight	
	in	mm	in	mm	in	mm	lb	kg
ZWM09207	0.5	12.7	4.75	120	22-31	559-787	45	20.5
ZWM12496	0.5	12.7	8.75	222	32 - 36	813-914	54	24.5

Slingco Part No.	Description
ZWM09741	Stay Wire Knob Replacement Kit - contains all parts needed to replace securement knobs

TRIPLEX DISPENSER



The Slingco Triples Dispenser is designed to be permanently mounted for the efficient dispensing of triplex. Slingco's triplex dispenser is designed to keep linemen safe while saving time and effort.

Constructed of high strength steel coated in a durable black and yellow finish allows the unit to endure the harsh outdoor environments. The high load sealed ball bearing keeps operation and rotation smooth.

Easily adjust break tension with a 3/4" wrench. Simple pull knob operation for loading of triplex coils.

Wire guide allows easy payout and rewinding of triplex.

Slingco Part No.	Coil OUTSIDE Diameter Range		Coil INSIDE Diameter Range		Coil Width Capacity		Weight	
	in	mm	in	cm	in	cm	lb	kg
ZWM09903	26 - 32	66 - 81.3	14 - 20	35.5 - 50.8	10.25	26	54	24.5

3K STRAP HOIST



Use the Slingco 3k Strap Hoist to splice, dead end, and sag lines. The Slingco 3k Strap Hoist features an interlocking pawl lever system with dual pawl springs for controlled tightening and releasing of the strap and to ensure the hoist is engaged while in use. The strap hoist complies with ASME B-30-21 standard and all units are tested to 125% of load.

The Slingco 3k Strap Hoist uses pressure die castings for a professional look, consistent material properties, and smooth finish. The strap is hi-viz bright green in color for easy visibility. The strap hoist has three operating positions: lift/pull, lower/release, and freewheeling.

Slingco Part No.	Type	SINGLE LINE						DOUBLE LINE							
		Capacity		Lift		Headroom		Capacity		Lift		Headroom		Tool weight	
		lb	kg	ft	m	in	mm	lb	kg	ft	m	in	mm	lb	kg
ZLH10504	Standard	1,500	680	10	3	21	533	3,000	1,360	5	1.5	25	635	11.25	5.1
ZLH10524	Hot stick operated	1,500	680	10	3	18	457	3,000	1,360	5	1.5	25	635	11.5	5.22

CATCHBLOCK OHL CATENARY ROLLER

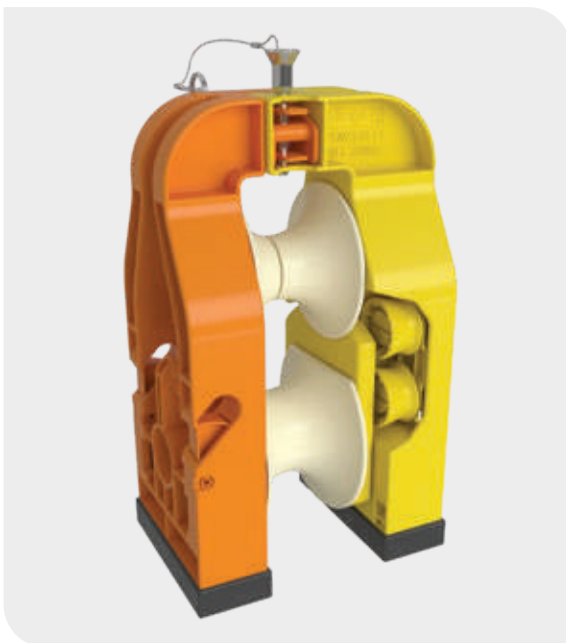

CatchBlock is an innovative overhead line (OHL) catenary roller system. Designed to deploy a two-rope system, it allows the recovery of broken conductors without the need to take possession of client/third party property or infrastructure.

Though the majority of off-the-shelf systems offer efficient single rope deployment, they frequently fail to meet the specifications required by third party clients who own property below overhead conductors. The CatchBlock system not only satisfies the most demanding requirements, but also - because it removes the need to close down essential infrastructure for conductor repairs or in the event of an emergency - its use means that estimating the costs of maintenance and refurbishment schemes is made far easier and more accurate.

KEY PRODUCT FEATURES

- Ropes are secured in position in the CatchBlock frame, avoiding the need for ferrules to be moulded or bonded to their outer surface
- Both ropes are tensioned simultaneously, hence the CatchBlock does not turn or flip
- Ropes are controlled to avoid build-up of slack in any sub-spans
- Both ropes are identical and have the same external marking to indicate where the CatchBlock is to be fitted
- One rope is contained in the main housing of the CatchBlock, the frame needs to be opened to allow the second rope to be installed

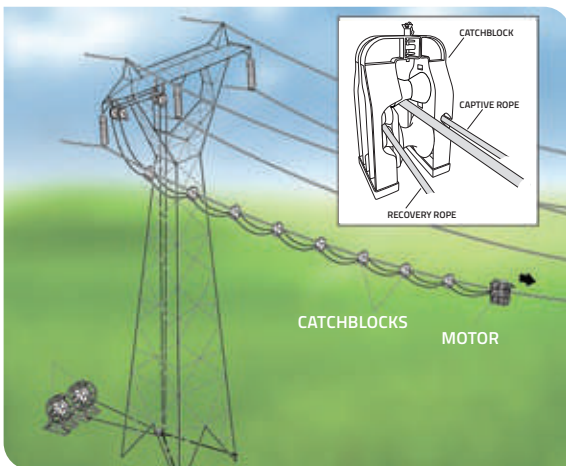

CatchBlock being deployed across the M1 Motorway in UK, replacing Zebra (ACSR) for 27mm for Araucaria 37mm (AAAC). 220kV Leicester Main Line Upgrade Project July 2021.



CONDUCTOR REPLACEMENT ROLLER



The Conductor Replacement Roller (CRR) provides a simple, conductor-deployed protection system using a lightweight aramid rope.

The CRR unit enables the safe exchange of conductors in three easy steps:

1. Laying out the pulling cable, e.g. with an electric pulling robot.
2. Tensioning the CRR Block assembly.
3. Feeding a new conductor through the cable pulleys of the CRR Block.

The CRR rollers have spring loaded gripping feature to secure the rope laterally without impinging any rotational movement as the rollers rotate around the axis of the conductor. Considerable effort has been made to reduce the complexity of the design to provide a simple mechanism to hold the rope and then connect around the conductor.

Designed for rapid deployment and secure connection the external locking mechanism can be inspected from ground level.

- 30% glass filled Nylon 6 from bespoke mould tooling
- Bespoke design incorporates aperture of 65mm to accept smooth passage of joints and connectors
- Type registered to industry standards
- Non conductive through use of insulating materials

ROBLON HIGH VOLTAGE PULLING ROPE



Roblon HVPR was initially designed for live-line stringing using the cradle-block method, but its excellent dielectric properties enable it to be used as helicopter longlines, guy lines for transmission towers and short-haul lines for work in energised electrical environments, and other applications.

Roblon HVPR is a dielectric rope used for stringing and service operations, for installing OPGW, and similar operations. The rope is torque balanced and lightweight.

Roblon HVPR is manufactured from high performance aramid fibres with a thermoplastic polyurethane (TPU) coating. Roblon HVPR is available in four dimensions as standard (if other types are required, please contact us).



Diameter	9 mm (0.35 in)	13.85 mm (0.55 in)	16 mm (0.24 in)	20 mm (0.79 in)
Breaking strength (minimum)	>35 kN (7,868 lb)	>85 kN (19,108 lb)	>130 kN (29,225 lb)	>200 kN (44,961 lb)
Weight per metre (nom.)	68 g/m (2.4 oz)	162 g/m (5.7 oz)	230 g/m (8.1 oz)	343 g/m (12.1)
Elongation at break	3.6%			
Thermal expansion factor	-4.5 x 10 <sup>-6</sup>			
Cross section area (outer)	63.6 mm <sup>2</sup> (2.5 in <sup>2</sup> )	150.6 mm <sup>2</sup> (5.9 in <sup>2</sup> )	201.0 mm <sup>2</sup> (7.9 in <sup>2</sup> )	314.2 mm <sup>2</sup> (12.4 in <sup>2</sup> )
Cross section (fibre core)	43.0 mm <sup>2</sup> (1.7 in <sup>2</sup> )	117.9 mm <sup>2</sup> (4.6 in <sup>2</sup> )	133.0 mm <sup>2</sup> (5.2 in <sup>2</sup> )	265.9 mm <sup>2</sup> (10.5 in <sup>2</sup> )
Stiffness	1,200 kN (269,770 lb)	3,900 kN (876,755 lb)	6,500 kN (1,461,258 lb)	12,000 kN (2,697,708 lb)
Final modulus of elasticity	18.8 GPa	26.4 GPa	32.7 GPa	38.6 GPa

## MULTI-FUNCTION CABLE ROBOT



Slingco's Multi-Function Cable Robot is a remotely operated, motorised aluminium chassis tug unit for the purpose of changing out de-energised overhead power cables or ground wires. The compact unit is powered using a rechargeable li-ion battery which makes for quick onsite changeover in remote areas and designed to be used with conductor replacement systems and inspection devices. The unit comes complete with a standard recovery device.

- Max tractive effort 60 kg, up to 40 kg on a 20 degree incline on a 20mm diameter conductor\*
- Automatic soft start - 4 kph with a run time 120 minutes from fully charged battery
- 2 driven rubber tyred wheels via a compact 18V – 12Ah battery
- 433MHz radio remote control 500m range
- Operates on conductors/ropes ranging from Ø 14 – 55mm
- Smooth transition over mid-span joints/connectors
- Bi-directional travel with enclosed motor and drive units
- Designated lifting point
- Fully recoverable at both ends

\* Tractive effort will be increased on larger diameter conductors

Slingco Part No		Dimensions	Weight
ZSN13024	MFCR	700mm x 400mm x 300mm	31kg (inc. battery)
	Rechargeable Li-ion Battery		3kg
ZSN13024	Recovery device	420mm x 300mm x 200mm	14.5kg

## BOLLARD CLAMP

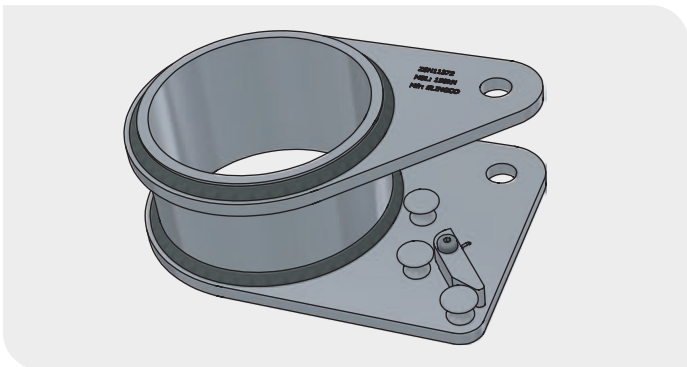

The Bollard Clamp is an easy to use tensioning device that can be used without risk of damage to the tensioned rope. This is a major advantage over standard types of gripping devices, which could potentially crush or compress the rope or its outer coating.

Installation of the Bollard Clamp is simple, requiring no tools, and the device can be fitted anywhere along the length of the rope using a spring-loaded rope captivation lever. One installed, the clamp utilises the friction created over a large area of the rope to enable the required tension to the specified WLL.

- Tension without damage to rope, outer coating or underlying layers
- Secures the rope up to 3x WLL
- Weighs only 3kg
- Suitable for ropes 12-20mm diameter

Slingco Part No.	WLL	Proof load	MBL	Material	Weight	Barrel diameter	Rope suitability
ZSN11372		25.5kN	51kN	Aluminium (6082/1050)	3 kg	200mm	12-20mm

Figures given above are indicative only. Nominal figures/actuals are as per datasheet with tolerances of +/-5%. Datasheets available on request.

## FIBREGLASS EXTENSION ARM



Slingco's Fibreglass Extension Arm is designed to be used in situations such as moving out conductors to create working clearance in congested areas, or as a temporary aid in replacing insulators, and/or replacing existing conductors.

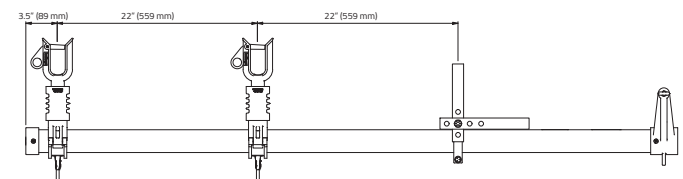

Slingco Part No.	Arm Dia./Length in (mm)	Phase-to-Phase Rating	Max. Vertical Load per Wireholder lb (kg)	Weight lb (kg)	Replacement Eye Screw
ITP10989	2.5" x 72" (63.5 x 1,828.8)	15kV	150 (68.04)	9.62 (4.36)	EBW09611
ITP10474*	2.5" x 72" (63.5 x 1,828.8)	34.5kV	150 (68.04)	10.61 (4.81)	EBW09611

\*ITP10474 34.5kV version includes insulators

# DISTRIBUTION STRINGING BLOCKS & ACCESSORIES

## LIGHTWEIGHT, RELIABLE AND VERSATILE

Slingco offer two lightweight, rugged, reliable and durable aluminium distribution stringing blocks. Used in conjunction with purpose-designed accessories, they have proven extremely popular with utility operators and their contractors for the exceptional versatility they offer in terms of installation applications and locations. Their low-friction bearings deliver high efficiency, which helps to maximise stringing distances while minimising pulling tensions and reducing loads on stringing equipment. We also offer three crossarm bracket options and various ball clevis attachments.

### 7" FLIP GATE ALUMINIUM DISTRIBUTION STRINGING BLOCK

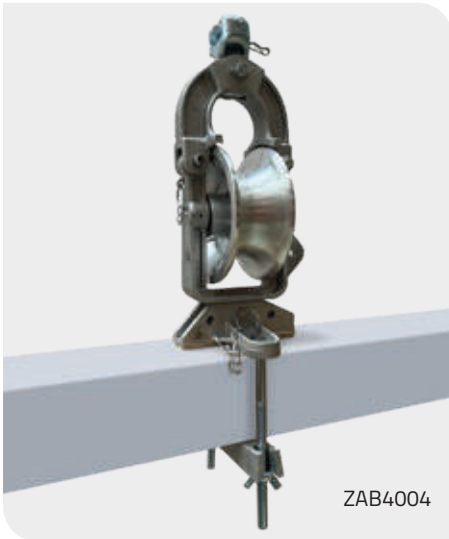

ZAB4004

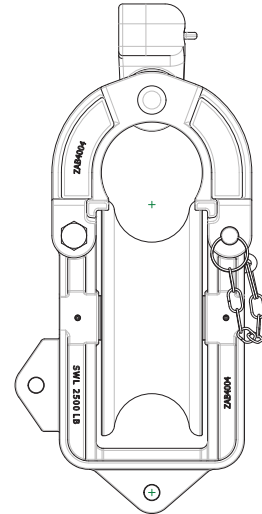
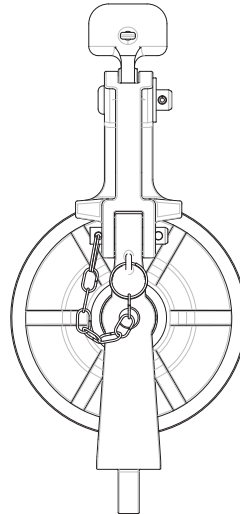

### 7" SPRING GATE ALUMINIUM DISTRIBUTION STRINGING BLOCK



ZAB4344

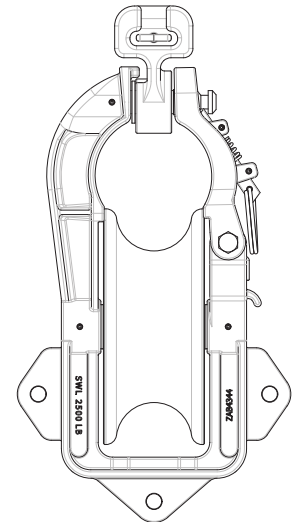
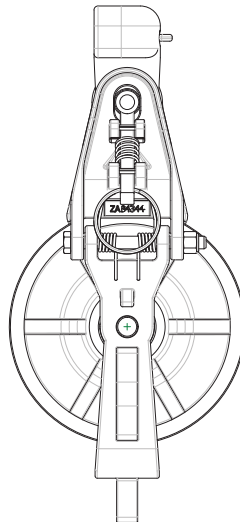

Slingco Part No.	Description	Weight		WLL		Height		Sheave Size		Bottom of Groove		Groove Radius	
		lb	kg	lb	kg	in	mm	in	mm	in	mm	in	mm
ZAB4004	7" Flip Top Aluminium Distribution Block	8.3	3.76	2,500	1,134	15.125	384.2	7	177.8	4.5	114.3	2.25	57.15
ZAB4344	7" Spring Open Aluminium Distribution Block	9.2	4.17	2,500	1,134	15.344	389.74	7	177.8	4.5	114.3	2.25	57.15



#### SOME DISTRIBUTION LIMITS APPLY

Please note some Slingco products are available only in specific markets and through limited distribution channels. Contact Slingco for product availability.

**PARTIAL FRAME**



ZMI10017

Slingco Cross Arm Brackets are designed for easy attachment of distribution blocks to cross arms. Securely mount distribution blocks to cross arms at three convenient angles based upon the needs of

**FULL FRAME**



ZMI10018

your pull. Quick release pin for attachment of distribution block. Fits most cross arm sizes. Two styles available: full frame (ZMI10018) and partial frame (ZMI10017).

**RATCHET STRAP**



ZMI14338

Used in conduction with Slingco's Stringing Blocks, the Crossarm Ratchet Strap can be mounted on wooden, fibreglass or composite crossarms, as well as concrete, wood, or steel poles. This versatile crossarm bracket ratchet strap allows stringing blocks to be mounted horizontally or vertically. Strap length is 1300mm, with a WLL of 650kg.

**'Y' FITTING**



CSB09094

The CSB09094 is a galvanised Y-ball clevis with a curved holding bolt. The bolt is retained in the clevis body with a 1-1/8" hex nut and standard cotter pin. The curved holding bolt provides an additional point of manoeuvrability.

**'U' FITTING**



CSB09095

The CSB09095 is a galvanised standard U-ball clevis with a removable straight pin. The pin is held in place in the clevis body with a standard cotter pin.

Slingco Part No.	Description	SWL	
		lb	kg
ZMI10017	Crossarm Bracket - Partial Frame	2,500	1,133
ZMI10018	Crossarm Bracket - Full Frame	2,500	1,133
ZMI14338	Crossarm Bracket - Ratchet Strap	2,500	1,133
CSB09094	Ball Clevis - Y Fitting	2,000	907
CSB09095	Ball Clevis - U Fitting	2,000	907

All Slingco products are produced from the highest quality materials, each product is complete with warranty and certificate of conformity. For full specification please contact [sales@slingcoaustralia.com.au](mailto:sales@slingcoaustralia.com.au) for further details.

# 10K DRIVE WRENCH ASSEMBLY

## EFFICIENT INSTALLATION OF SCREW ANCHORS

Drive Wrench System for installation of screw anchors. Component and options include:

- Orange Drive Wrench (#SAE09639)
- Yellow Drive Wrench (#SAE08666)
- Square Shank Anchor Tool (#SAE11132)
- Drive Wrench Lock (#SAE10425)
- Square Drive Head Adapter (#SAE14309)
- 2.625 in Hex Kelly Bar Adapter (#SAE10427)
- 1.5 in Square Shank Bolted Assembly (#SAE13513)

Slingsco's 10k Drive Wrench Assembly is a tool system for the installation of screw anchors.

Designed to connect the square anchor of a drive motor or screw anchor to the hexagonal Kelly Bar of a bucket truck. System options include Drive Wrenches to suit different sized anchor rods; a Drive Wrench lock; two Kelly Bar Adapters to fit the hex drive bar's dimensions (2.5 in and 2.625 in) and one Square Head Kelly Bar Adapter to suit 3 in Square Drive Bar.

The Drive Wrench Lock attaches to the Kelly Bar Adapter and makes the installation of the Anchor Rod much easier. The three position rings of the lock assembly ensure easy capture of the Drive Wrench and Anchor Rod, holding them securely while under torque and releasing them when needed.

The Drive Wrenches are designed to allow Anchor Rods to telescope inside, and secure to, the Drive Wrench Lock. The Drive Wrench transfers the torque from the Drive motor to the Screw Anchor, and are rated to 10,000 ft-lb.

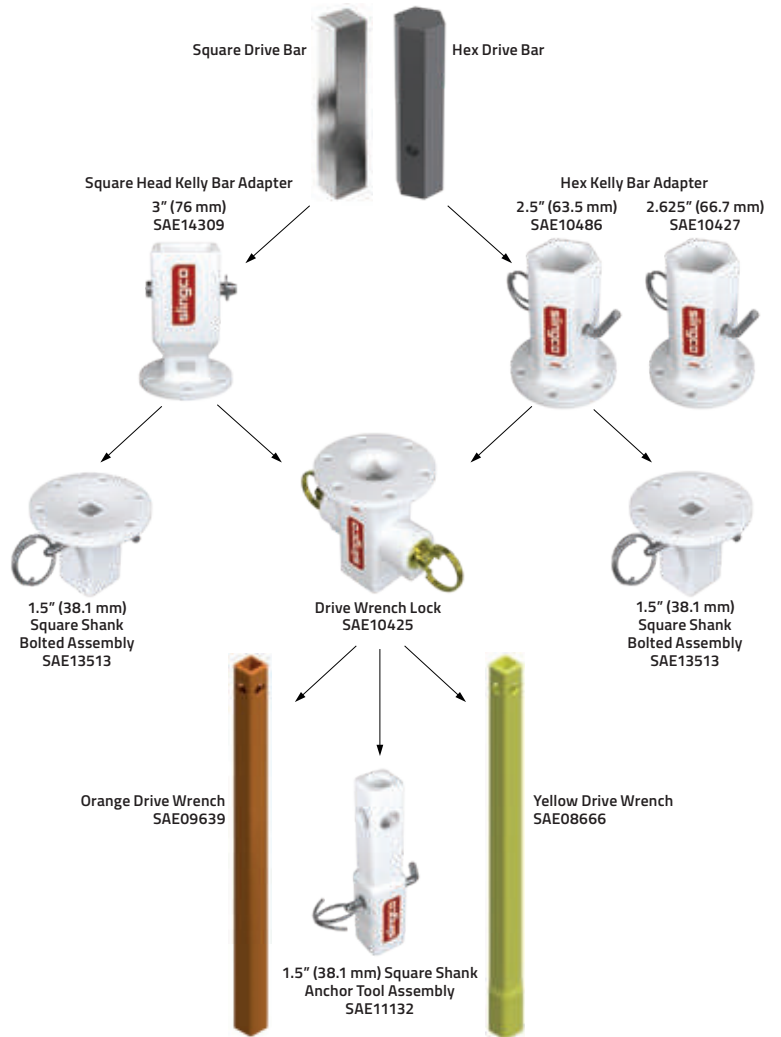

**HEX KELLY BAR ADAPTERS**



Slingco's Hex Kelly Bar Adapters are a key component in the Drive Wrench Assembly. The adapters are used to connect the Drive Wrench Lock Assembly to the Kelly Bar of the bucket truck. There are two versions available which fit the most common drive bar dimensions.

Slingco Part No.	Kelly Bar Shape	Adapter dimensions						Weight each	
		X		Y		Z		lb	kg
SAE10486	HEX	2.5	63.5	4.25	108	8.25	210	16.3	7.39
SAE10427	HEX	2.625	66.7	4.25	108	8.25	210	16.7	7.57

**SQUARE HEAD ADAPTER**



Slingco's Square Head Kelly Bar Adapters are a key component in the Drive Wrench Assembly. The adapters are used to connect the Drive Wrench Lock Assembly to the Kelly Bar of the bucket truck.

Slingco Part No.	Kelly Bar Shape	Description	Adapter dimensions				Weight	
			X		Y		lb	kg
SAE14309	SQU	76 x 76 mm Square Head Adapter	3	76	9.4	240	16.5	7.5

**DRIVE WRENCH LOCK ASSEMBLY**



Slingco's Drive Wrench Lock Assembly attaches to the adapter and makes the installation of the anchor rod much easier. The three-position rings allow for easy capture of the Drive Wrench and the anchor rod, holding them securely while under torque, and releasing each when needed.

Slingco Part No.	Description	Weight	
		lb	kg
SAE10425	Drive Lock Assembly	18.4	8.35
SAE13513	1-1/2" Square Shank Bolted Assembly		

**DRIVE WRENCHES**



Slingco's Drive Wrenches are designed to allow anchor rods to telescope inside them, and securing to the Drive Wrench Lock Assembly. The Drive Wrench transfers the torque from the drive motor to the screw anchor.

Rated to 10,000 ft-lb of torque, Slingco's Drive Wrenches are tough and can handle anchor installs in tough environments.

Slingco Part No.	Description	Hub Size		Shaft Size	
		in	mm	in	mm
SAE09639	10,000ft-lb Orange Drive Wrench	2.25	57	1.375	35
SAE08666	10,000ft-lb Yellow Drive Wrench	2.5	63.5	1.5	38
SAE11132	1-1/2" Square Shank Anchor Tool Assembly				

57 lb (28.85 kg) is the weight of each Drive Wrench



**CROSS COUPLING PROTECTORS**



Slingco Cross Coupling Protectors are available in a variety of materials and configurations to protect cables and capillary tubing traveling down-hole. Customized variations allow for any cable/cap string configuration needed. Low Carbon Steel, various Stainless Steel, Inconel, Monel and other materials options available to match the requirements of your well composition. Contact Slingco for guidance on selecting the proper protector for your well.

- Various cable configuration options available
- Standard and low profile models
- Easy installation
- Securely holds and protects lines
- Special and custom features available

Tubing size	1st Cable	2nd Cable	3rd Cable	Material
2 3/8" to 13 3/8"	Various Round or Flat	Various Round or Flat	Various Round or Flat	Low Carbon Steel Zinc Passivated
2 3/8" to 13 3/8"	Various Round or Flat	Various Round or Flat	Various Round or Flat	304 SS
2 3/8" to 13 3/8"	Various Round or Flat	Various Round or Flat	Various Round or Flat	316 SS
2 3/8" to 13 3/8"	Various Round or Flat	Various Round or Flat	Various Round or Flat	410 SS
2 3/8" to 13 3/8"	Various Round or Flat	Various Round or Flat	Various Round or Flat	1Cr13
2 3/8" to 9 7/8"	Various Round or Flat	Various Round or Flat	Various Round or Flat	Inconel
2 3/8" to 9 7/8"	Various Round or Flat	Various Round or Flat	Various Round or Flat	Monel

**GAUGE & SPLICE PROTECTORS**



Slingco Gauge Carrier and Splice Protectors securely support equipment down hole. These designs are made to your specifications to match the tubing and casing dimensions needed. Gauges are supported within the channel of the protector with the appropriate cables entering and exiting as needed. These protectors may be run mid-joint (between couplings). These protectors can be made in a variety of materials to meet your well's needs.

- Sized for the gauge or splice
- Multiple materials available from low carbon steel to Inconel
- Designed to run mid-span on tubing between couplings
- Custom designs available

**DUAL CHANNEL CROSS COUPLING PROTECTORS**

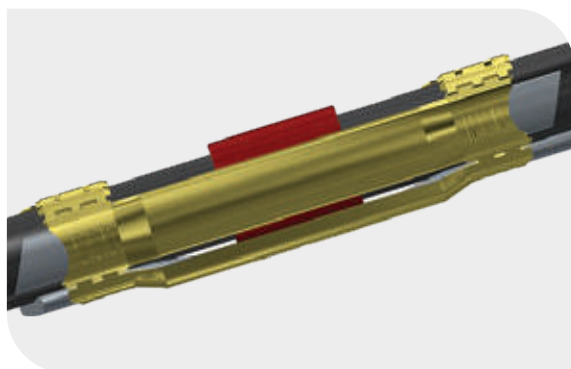

Slingco Dual Channel Protectors increase the number of cables that may be protected by adding a second channel to the cable protector. They can accommodate multiple ESP cables plus additional cap lines or control cables. As with standard cross coupling protectors these may be made in a variety of materials and configurations to protect cables and capillary tubing traveling down hole. Customized variations allow for any cable/cap string configuration needed. Low Carbon Steel, various Stainless Steel, Inconel, Monel and other materials options available to match the requirements of your well composition. Contact Slingco for guidance on selecting the proper protector for your well.

- Easy Install hinge design
- Standard and low profile models
- Securely holds and protects lines
- Special and custom features available

MID-JOINT CABLE PROTECTORS



The Mid-Joint Cable Protector is installed between joints of down-hole tubing strings, and is often used in conjunction with other cable protectors to further secure and protect cables or lines from damage.

- Used between the joints
- Offers additional securement and protection of the cables

CENTRALISING CABLE PROTECTORS



This versatile 'hybrid' product is designed to fulfil the dual role of cable protection and centralisation, ensuring both can be achieved as quickly and efficiently as possible. As with the other cable protectors in our range, the Centralising Cable Protector is available in standard and specialized configurations.

- Standard range and also bespoke options
- Quick and Efficient installation performing the dual role of centralising and protecting

BANDED CABLE PROTECTORS



These lightweight, stamped steel protective cable guards offer a compact, low-cost alternative to our standard Cable Protectors. Designed for use in shallow wells with little to no deviation, the protectors are situated across the coupling and attached to the tubing string with steel bands.

- Lightweight
- Low cost alternative
- Suitable for shallow wells or ones with minimal deviation

Tubing size	Cable Options	Material	Custom Configurations?
2 3/8" to 2 7/8"	.125" to .625" round or flat	Low Carbon Steel, SS	YES
3.5" - 4.5"	.125" to .75" round or flat	Low Carbon Steel, SS	YES
5.5 - 7.0"	.125" to 1.25" round or flat	Low Carbon Steel, SS	YES



## BOW SPRING CENTRALISERS



Specially designed for vertical wells where low principal forces and high restoring forces are required, this one-piece design simplifies installation onto casings. The Bow Spring Centraliser is available in multiple sizes and blade configurations.

- One-piece design
- Simplifies installation
- Multiple sizes and configurations

## RIGID CENTRALISERS



Designed to ensure concentricity and standoff in deviated and horizontal wells, this one-piece centraliser minimises differential sticking. As with other centralisers in our range the Rigid Centraliser is available in multiple sizes and blade configurations.

- One-piece design
- Minimises differential sticking
- Multiple sizes and configurations

## CABLE PULLING SOCKS AND CABLE SUPPORT SOCKS

### ASSESSMENT OF SUITABILITY

There are many factors that must be taken into account when assessing the suitability of a cable sock for a proposed application and trying to calculate a safe working load. These include:

- Size of cable sock in relation to size/shape of gripped object(s)
- Stability of object(s) when gripped
- Grip surface of object(s)
- Resistive force of object(s)
- Anticipated path of movement, including possible obstructions
- Approximate breaking strength of the cable sock
- Condition of cable sock
- Suitability and compatibility of any attachments used
- Environment / operating conditions
- Persons at risk

If you have any questions regarding suitability for any particular application please call the distributor who supplied the cable sock or our in-house Technical Department.

*Please note:* Slingco cable socks must be double steel banded securely before being pulled.

### LATTICE DIMENSIONS

Lattice dimensions shown are as fitted to a nominal diameter of cable and prior 'free length' may be slightly longer than stated.

### APPROXIMATE BREAK LOAD

This is the calculated average based on actual testing done by Slingco. Approximate break loads are quoted as a guide only.

### TYPICAL CONFIGURATIONS

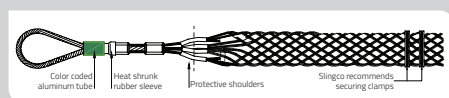

### SAFE WORKING LOAD

Application load is normally calculated to be reduced by at least a factor of 5x the Approximate break load. Due to the wide variety of application parameters, the end user must apply a sensible safety factor to suit the safety requirements for the conditions of use.

The Safe Working Load (SWL) of a Slingco cable sock will depend on the Factor of Safety (FOS) applied to the Minimum Breaking Load.

### FACTOR OF SAFETY (FOS)

Where the operational risk is considered to be normal, it is recommended that a FOS of 5 be applied, for a high risk operation a FOS of at least 10 should be considered. It is impossible to catalogue or guarantee a safety factor that will apply for all applications.

Approximate Break Loads stated on any certification, the recommended Factors of Safety, and any implied or stated fitness for purpose, are all only applicable when the cable sock is as new and unused.

A 20% variance in break loads must be allowed for when selecting a cable sock; a suitable swivel must be used if there is 'twist' in the cable.

Torsional stress must be dealt with when using socks for line pulls and wire splices. When twisting forces are present use a swivel that rotates under load to release torsional stress.

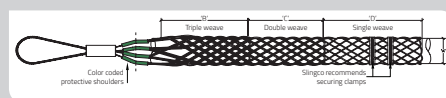

## Cable Sock Safety Information

- Ensure that the cable sock mesh fits conductor correctly
- Ensure that the conductor fits up to the mid-point of the protective shoulder
- Clamp the ends of the cable sock when attaching the conductor. We recommend between 1¼" and 2¼" from the end of the cable socks
- SECURE CLAMPING MUST BE USED ON SLINGCO CABLE SOCKS
- Never modify or attempt to repair any sock
- Ensure proper maintenance of the cable sock. If in doubt call +61 (0)3 8840 6556
- Check the condition of the cable sock, and that it is the correct size for the intended application - do not exceed the rated capacity
- Socks that are worn, bent or otherwise damaged should not be used
- Socks are only to be used for temporary installations
- Pulling devices should only be attached via the pulling eye
- Cable socks must only be fitted and used by trained competent person(s)



SLINGCO CABLE SOCKS MUST NOT BE USED TO THEIR APPROXIMATE BREAKING STRENGTH. A SENSIBLE SAFETY FACTOR MUST ALWAYS BE USED. IF IN DOUBT CONTACT THE MANUFACTURER OR THE DISTRIBUTOR THAT SUPPLIED THE SOCK!

If you have any questions regarding suitability for any particular application please call +61 (0)3 8840 6556.



# IMPORTANT TECHNICAL INFORMATION

## SINGLE AND DOUBLE EYE CABLE SOCK INSTRUCTIONS

**PLEASE NOTE:** The condition of the cable sock should always be checked prior to use. The correct size of sock should always be used for the intended application. The rated capacity of the sock should never be exceeded. Socks that are worn, bent or otherwise damaged should not be used.



Select the correct sock for the diameter of the conductor.

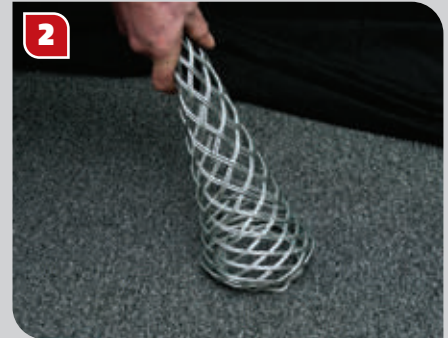

Prior to use, the lattice at the end of the sock needs to be widened. This can be easily achieved by pressing the end of the sock against a hard surface, which causes the lattice to expand.



The sock should then be pushed over the end of the conductor...



...and pushed over the conductor.



The sock then needs to be pushed along so that all the lattice is in contact with the conductor.



Once the cable sock is in place on the conductor, two clamps should be fitted to the end of the sock (as shown). We recommend between 1 ¼" (30mm) and 2 ¼" (55mm) away from the end of the cable sock.



Tape should then be wound around the end of the cable sock furthest away from the eye ends.



This will prevent the cable sock from snagging when in use.

## LACE UP CABLE SOCK INSTRUCTIONS

**PLEASE NOTE:** The images shown here use double weave cable socks. When lacing single weave cable socks please use single wire lace; use double-laced for double weave cable socks; and use triple-laced for triple weave cable socks.



Start the lacing from the 'eye' end or anchoring end of the cable sock.



Thread the lace through the first two loops of the split and pull through until the laces are centered at this point.



Don't pull the lace too tight at this stage. Leave a space between adjoining loops roughly equal to the width of one diamond of the mesh.

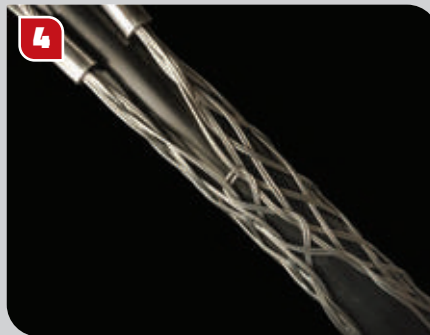

Continue down the length of the cable sock. Try to maintain equal tension and equal spacing throughout as this leads to a more stable and equal sock.



As you continue down the length, pull the open sides of the sock as wide apart as required.



Try to achieve an even and neat lace-up as this assists with the strength of the sock when pulling.



Finally, tie the ends of the lace once or twice round the end of the cable sock twisting the ends together securely. Excess lace can be cut off.

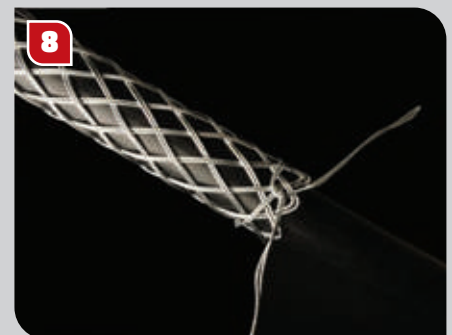

Add any additional support as required – banding is recommended. The Slingco cable sock is now ready to use.

# SLINGCO AUSTRALIA IS OPEN FOR BUSINESS! SERVING THE ENTIRE ASIA-PACIFIC REGION



As part of our major global expansion plans, we're now serving the whole of Australia, New Zealand and our trusted distribution partners across Asia-Pacific from our new sales & distribution centre in Melbourne, VIC, Australia.

We are one of the world's leading cable pulling and support sock manufacturers, working through specialised distribution partners across 70 countries to supply high quality performance products to key industries such as Transmission & Distribution Networks, Telecom, Construction, Mining, and Oil & Gas.

Hundreds of lines available ex-stock, including:

- Standard pulling socks (single eye, double eye, offset eye, lace-up)
- Non-metallic pulling socks
- Hose restraint socks and whipchecks
- Aerial conductor pulling socks
- Swivels and connectors
- Hydraulic crimper & dies
- Pole stands and pole pullers
- Drive wrench / kelly bars and locking dogs
- Stringing blocks and pulley blocks
- Dirt tarps, drum lifters and more

SUPPORTING APAC  
CUSTOMERS FROM  
OUR NEW SALES  
AND DISTRIBUTION  
CENTRE IN  
MELBOURNE, VIC



[slingcoaustralia.com.au](http://slingcoaustralia.com.au) · [sales@slingcoaustralia.com.au](mailto:sales@slingcoaustralia.com.au) · +61 3 8840 6556



FOR ANY ENQUIRIES CALL TODAY ON  
**+61 3 8840 6556**

**Slingco Australia Pty. Ltd.**

L9, 1 York Street, Sydney, NSW 2000, Australia  
Tel: +61 3 8840 6556 · sales@slingcoaustralia.com.au



**[slingcoaustralia.com.au](http://slingcoaustralia.com.au)**