

RUBBER BLANKET ACCESSORIES

SAFELY HOLD RUBBER INSULATING BLANKETS AND COVER-UPS IN POSITION

RUBBER BLANKET CLAMP PIN



Used to hold insulating blankets and other types of rubber cover-ups in place, the Slingco Blanket Clamp Pin is constructed of ultraviolet stabilised fibreglass reinforced polymer.

Extra holes in the centre of the body are used to grip conductors and prevent linehose from sliding. Holes have also been placed in the handles to enable attachment of warnings, tags, and/or flags.

The handles of the pin are shaped to engage with the end ferrule of a clampstick (shotgun stick).

WARNING

Cancer and Reproductive Harm
www.P65Warnings.ca.gov

Slingco Part No.	Length		Jaw Opening		Weight		Note
	in	mm	in	mm	oz	g	
ZPE10962	9.5	241	5	127	5	141.7	
ZPE12136	9.5	241	5	127	5.4	153	with Hot Stick Clip

- Constructed of ultraviolet stabilised fibreglass reinforced polymer
- Shotgun Stick compatible
- Convenient holes in handles to attach warnings, tags, and/or flags

slingco[®]

POLE CLAMP

ZPE11398



Slingco Pole Clamps are used to hold insulating blankets and other types of cover-ups in place while performing work and is constructed of ultraviolet stabilised fibreglass-reinforced polymer.

Slingco's Pole Clamps are meant to eliminate the use of tie wraps, bungee cords, tapes or any other items that can cause damage to insulated rubber products.

With Slingco's unique tool handle lock system, the Pole Clamp can be set in an open position by engaging the handle lock. Once the product is in its intended location the lock can be released making installation easier.

- Unique handle lock system for easier installation
- Made of ultraviolet stabilised fibreglass-reinforced polymer
- Available in two different sizes

WARNING
Cancer and Reproductive Harm
www.P65Warnings.ca.gov

Slingco Part No.	Length		Width		Jaw Opening		Weight	
	in	mm	in	mm	in	mm	lb	kg
ZPE11399	20.25	514.4	8.25	203.2	13.5	342.9	1.7	0.77
ZPE11398	28	711.2	11.5	291.2	19.75	501.7	2.2	1.0

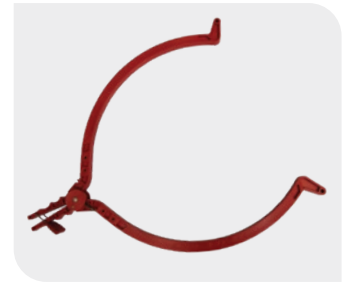

BLANKET MAGNET



The Slingco Blanket Magnet is constructed of ultraviolet-stabilised fibreglass reinforced polymer. This reinforced polymer remains strong and resists breakage, providing a long life for the tool.

The Slingco Blanket Magnet is designed to fit through the eyelets of an insulated blanket. Afterwards, the magnet along with the blanket can be placed over energised areas of transformers, switchboards and substations.

Can be used with hot line tools.

- Hold insulating blankets in place
- Easily insert through blanket eyelets
- Hotstick moveable

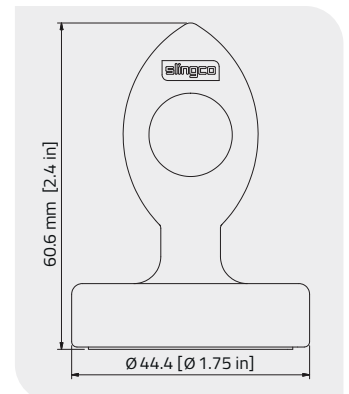

Slingco Part No.	Height		Diameter		Weight		Magnet rating	
	in	mm	in	mm	lb	g	lb	kg
PPE10785	2.4	60.6	1.75	44.4	0.2	90.7	120	54.4

WARNING
Cancer and Reproductive Harm
www.P65Warnings.ca.gov

FOR ANY ENQUIRIES CALL TODAY ON
+61 3 8840 6556

Slingco Australia Pty. Ltd.
L9, 1 York Street, Sydney, NSW 2000, Australia
Tel: +61 3 8840 6556 · sales@slingcoaustralia.com.au



slingcoaustralia.com.au